



15 Electrical system of engine

Job No.

Alternator

Testing alternator with regulator in vehicle	15-600
Renewing fan assembly	642

Starter

Removal and installation of starter	700
A. Engine 102 with GF starter (without countershaft)	
B. Engine 102 with countershaft starter	
C. Engine 601	

Test values

Regulating voltage → regulator

Regulating voltage (on battery) Volts (nominal value)	Engine speed 1/min	Battery load	Battery acid density kg/dm ³ 1)	Regulating voltage measured after
13.0-14.5	3000	Compulsory consumers only (e.g. ignition)	normal min. 1.24 tropics min. 1.19	approx. 2 minutes

1) If battery state of charge is less than 1.24 kg/dm³ or 1.19 kg/dm³, the regulator will not operate in regulation range during test, but will fully excite alternator, that is, a defective regulator with continuous full excitation will not be recognized.

Charging current of alternator

Engine	Alternator designation 14 volts/..... amps	Engine speed ⁴⁾ 1/min	Charging current amps	Ratio Engine/Generator
102	55	2680	55	2.35
102 (USA)	65	2680	65	2.35
102 ¹⁾	55	2830	55	2.23
102 ¹⁾²⁾	55	2480	55	2.54
102 ¹⁾²⁾³⁾ (USA)	70	2480	70	2.54
601	55	2830	55	2.23
601 ²⁾	55	2480	55	2.54
601 ²⁾³⁾	70	2480	70	2.54
602 ²⁾	55	2480	55	2.54

1) Single-belt drive

2) With power steering

3) With air conditioning and Tempmatic climate control

4) Engine speed = alternator speed of 6300/min

Note: When checking charging current at 6000/min of alternator the voltage should not drop below 12.7 volts.

With engine stopped

1 Check battery and alternator connections, as well as grounding strap between engine and body for tight seat and perfect condition. In addition, check V-belt tension and pay attention to charge indicator lamp (Nom.: Key position 2 = check lamp on; Key position 0 and 1 = check lamp off).

2 As a prerequisite for measuring regulating voltage, check acid density of battery in all cells.

Required values: normal min. 1.24 kg/dm³
tropics min. 1.19 kg/dm³

3 If discharge is **supected**, test battery discharge current (all consumers switched off, pay attention to time clock and consumers with rest potential input).

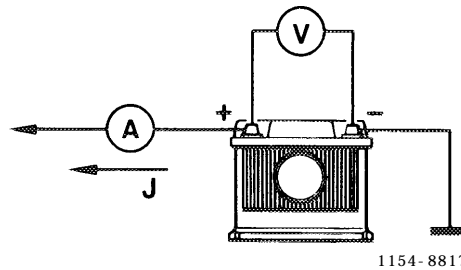

With engine running

4 Pay attention to charge indicator lamp at idle and at increasing engine speed (up to approx. 3000/min) — light should go out.

5 Check regulating voltage. Acid density of battery should amount to at least 1.24 kg/dm³ or tropics 1.19 kg/dm³. Run engine at 3000/min. Load battery with compulsory consumers only (e.g. ignition). Read regulating voltage after approx. 2 minutes of operation.

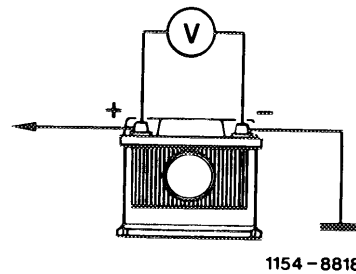

Nominal value 13.0-14.5 volts.

6 Testing charging current

a) with ammeter

Run engine at idle to respective alternator speeds (refer to Table).

Load battery with installed consumers or with load resistance until max. charging current is attained. Regulating voltage should not drop below 12.7 volts.

Note: If measuring proceeds according to connection diagram on battery, the previously supplied current for compulsory consumers, e.g. ignition, fuel pump, must be added to the battery current measured.

When using DC clip-on, the entire charging current can be measured on alternator.

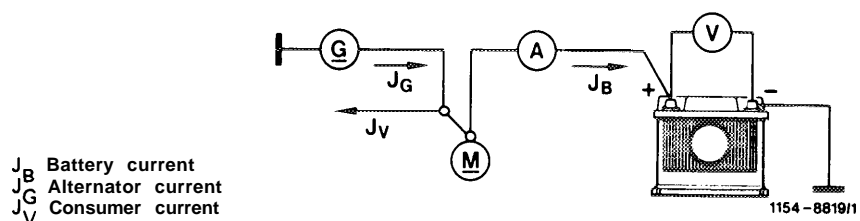

J_B Battery current
J_B Alternator current
J_G Consumer current
J_V

b) Diode test (harmony)

Evaluate harmony of regulating voltage (voltage flow) (measuring value or good/poor evaluation with oscilloscope). For this purpose, load battery with high beam at engine speed of 3000/min.

Alternator in order (voltage peaks possible – but without significance).

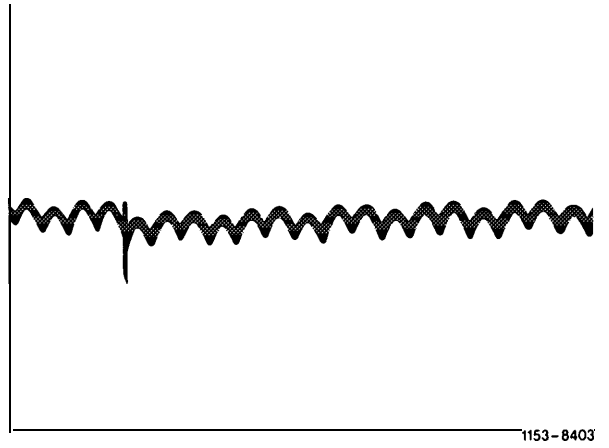

Alternator defective (example)

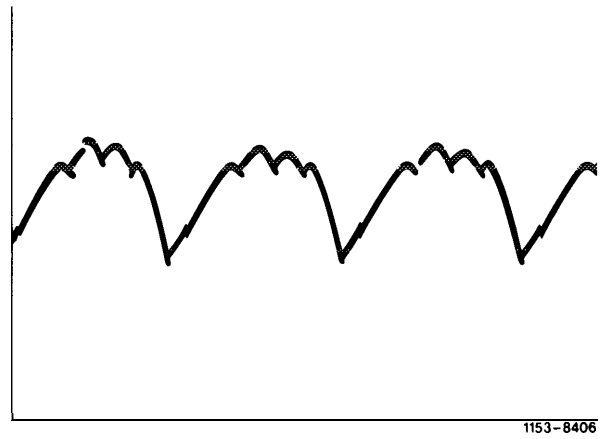

Tightening torques	Nm
Fastening nuts of fan assembly with divided pulley	35-45
Fastening nut of fan assembly with taper rib pulley	65 ± 5

Note

The fan disk is subject to considerably varying stresses. The extent of these stresses depends mainly on driving conditions. This is why, when reconditioning or exchanging alternators after driving for more than 100000 km, the fan assembly will also be replaced.

With divided pulley

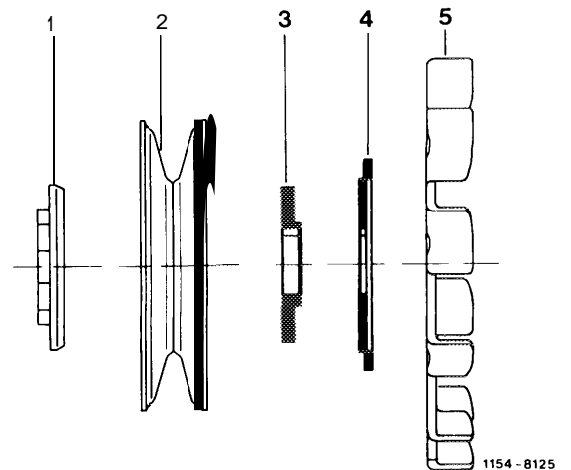

- 1 Front groove disk
- 2 2-piece pulley
- 3 Rear groove disk
- 4 Supporting disk
- 5 Fan disk

1154 - 8125

With taper rib pulley

Holder, part no. 126 589 00 40 00 can be used for holding pulley, if fitted with a segment from taper rib pulley.

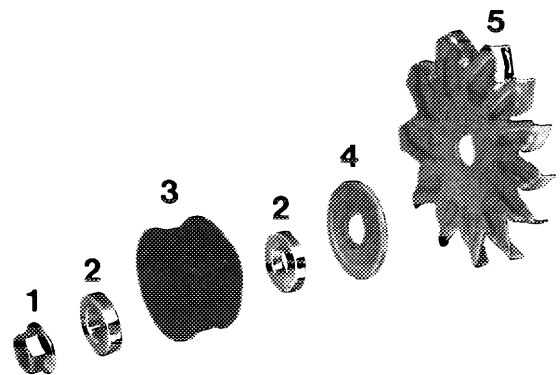

- 1 Flange nut
- 2 Spacing washer
- 3 Taper rib pulley
- 4 Supporting disk
- 5 Fan disk

115-26506

A. Engine 102 with GF starter (without countershaft)

Removal

- 1 Disconnect negative terminal of battery.
- 2 Remove air cleaner.
- 3 Remove intake manifold support.

Fastening of intake manifold support, top (arrows)

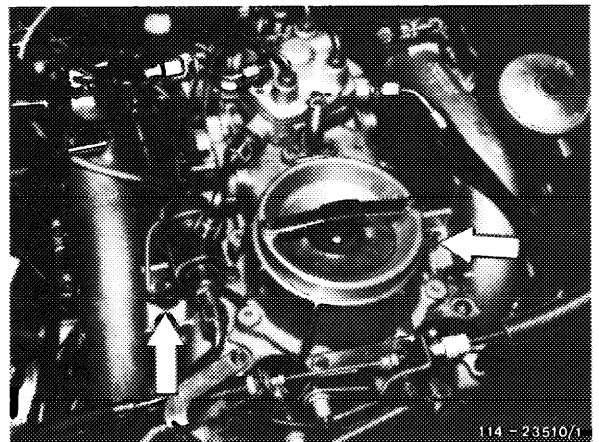

- 4 Disconnect return spring between throttle valve housing and intake manifold support.

Fastening (5) of intake manifold support, below

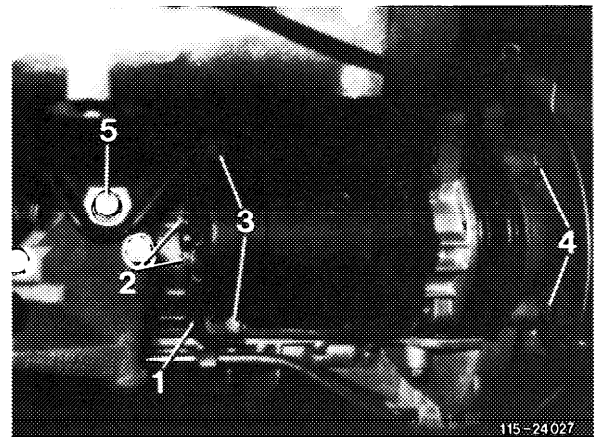

- 5 On vehicles with E-cruise control/tempomat, unscrew three fastening nuts of actuator, remove actuator from stud.

Note: The partial removal of actuator (E-cruise control/tempomat) is required because the starter must be turned as much as possible in direction of engine block during removal.

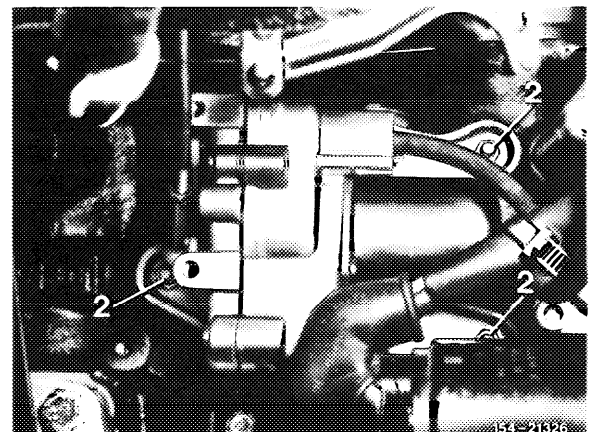

6 Unscrew support (1) on starter (2) and engine block (3).

7 Unscrew starter from transmission (4).

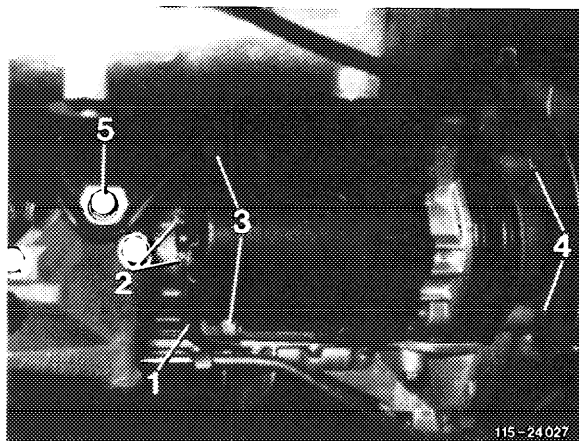

8 Pull drag link (11) from pitman arm (2).

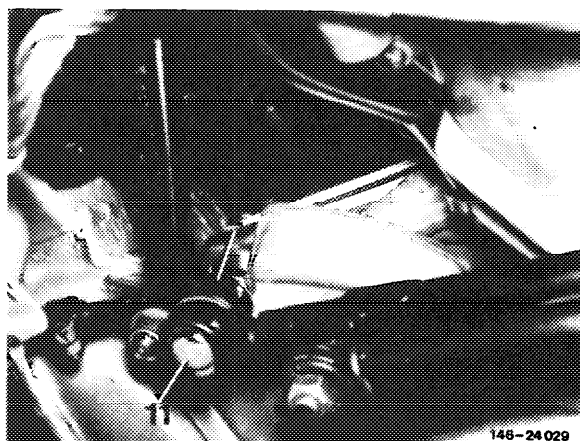

9 Remove battery positive line (1), loosen fastening rail (2) and holder (3).

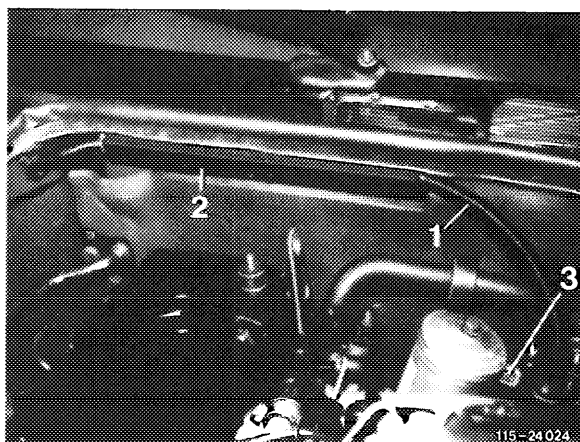

10 Unscrew lines, terminal 30 (color, red) and 50 (color, purple) on cable connector.

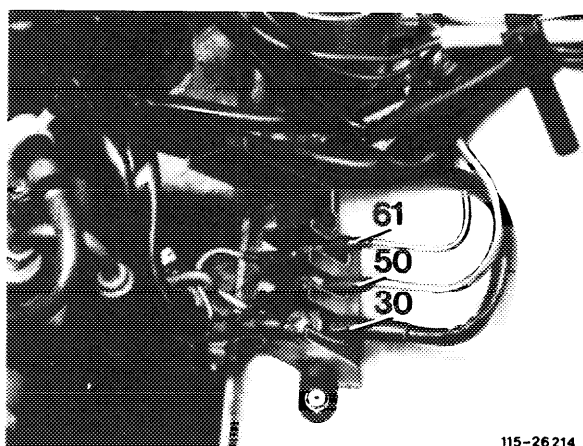

11 Turn steering wheel completely to the right.

12 Remove starter.

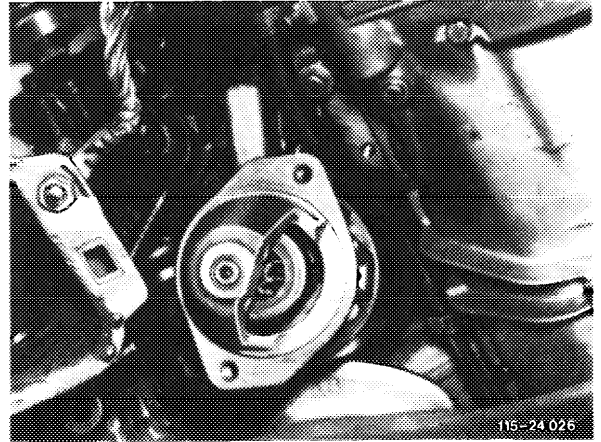

13 Disconnect electric lines on starter.

Installation

14 Connect electric lines to starter.

15 Introduce starter between steering and engine and screw to transmission.

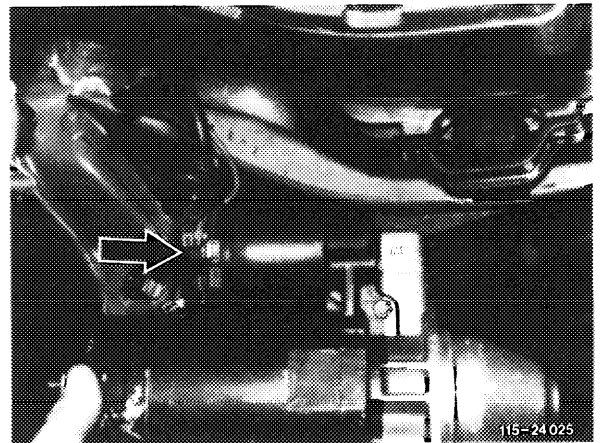

16 Install support for starter.

17 Mount actuator for E-cruise control/tempomat.

18 Mount intake manifold support and engage return spring on intake manifold support and throttle valve housing.

19 Connect line, terminal 30 and terminal 50 to engine cable connector.

20 Install battery positive line (1), screw holder (3) to oil filter and mount fastening rail (2).

21 Mount drag link (11) on pitman arm (2).

22 Mount engine compartment lining.

23 Install air cleaner and connect negative terminal of battery.

3. Engine 102 with countershaft starter

Removal

1 Disconnect negative terminal of battery.

2 Remove engine compartment lining below (if existing).

3 Remove air cleaner (model 201.024).

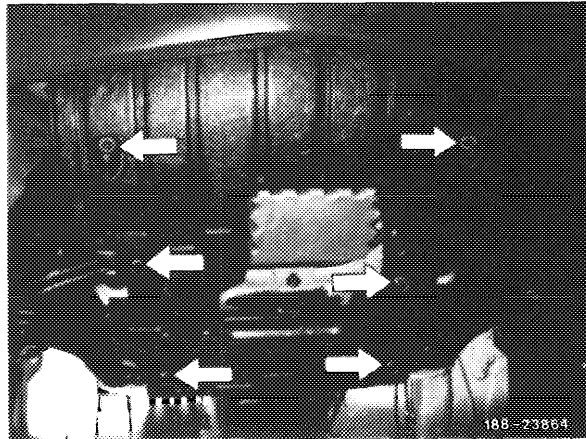

4 Unscrew starter from transmission.

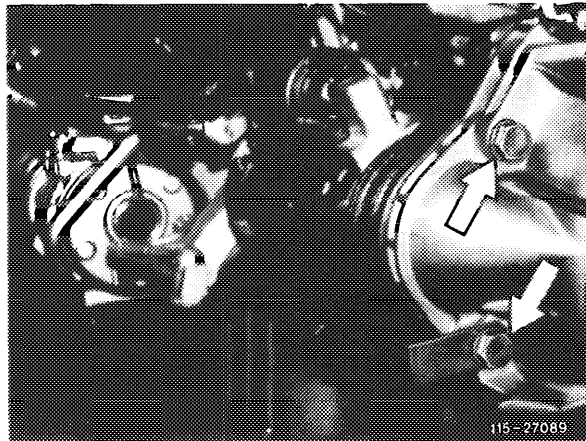

5 Loosen holder on intake manifold.

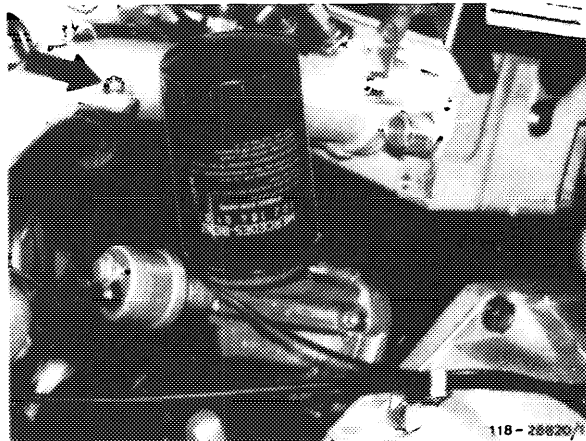

6 Pull plug from oil level indicator (arrow).

7 Turn steering wheel to the right,

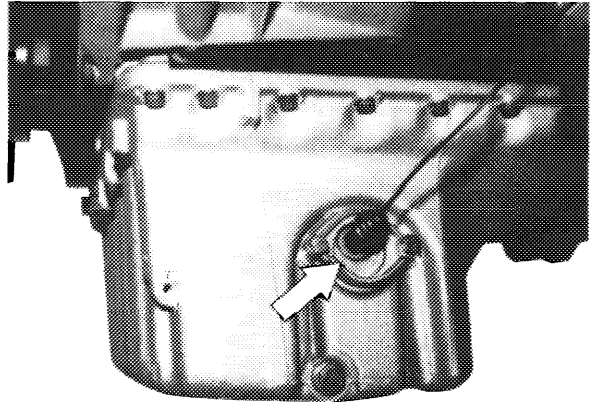

101 • 28890/1

8 Slightly pull out starter.

9 Disconnect electric lines on starter.

10 Remove starter.

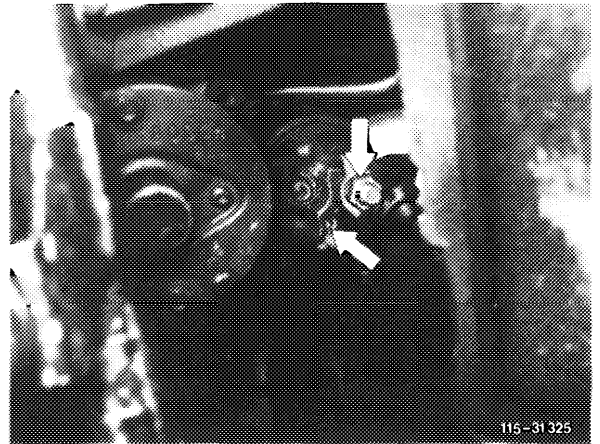

115 - 31 325

Installation

For installation proceed vice versa.

C. Engine 601

Removal

- 1 Disconnect negative terminal of battery.
- 2 Completely remove air cleaner (09-400).
- 3 Disconnect electric lines terminal 30 and terminal 50 on starter.

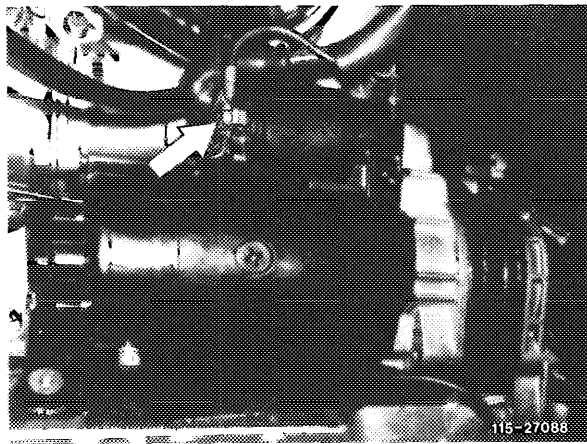
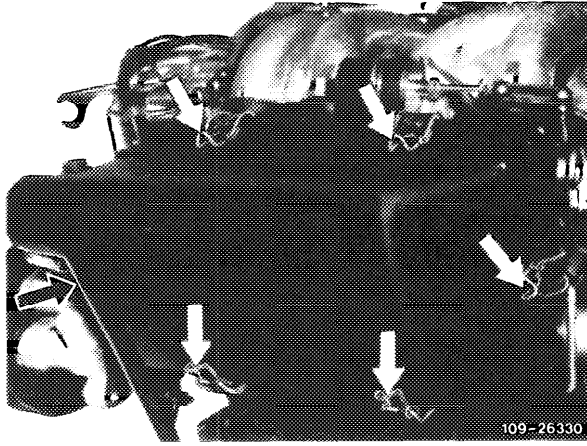

- 4 Remove noise capsule rear (2).

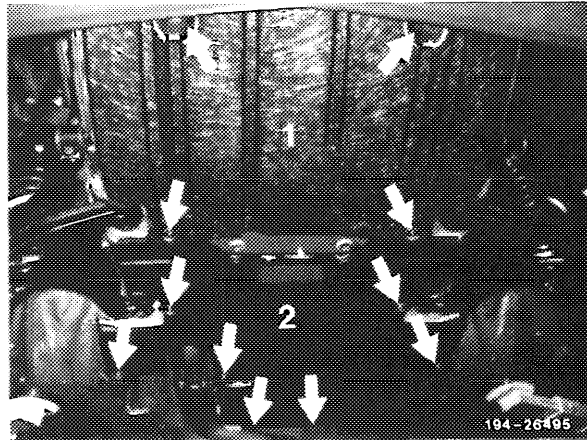

- 5 Unscrew fastening screws of starter on transmission and remove starter in upward direction.

Installation

For installation proceed vice versa.

