

09 Air cleaner

	Job No.
Removal and installation of air cleaner	09-400
A. Standard version and (USA) Federal	
B. @California	

09-400 Removal and installation of air cleaner

A. Standard version and  Federal

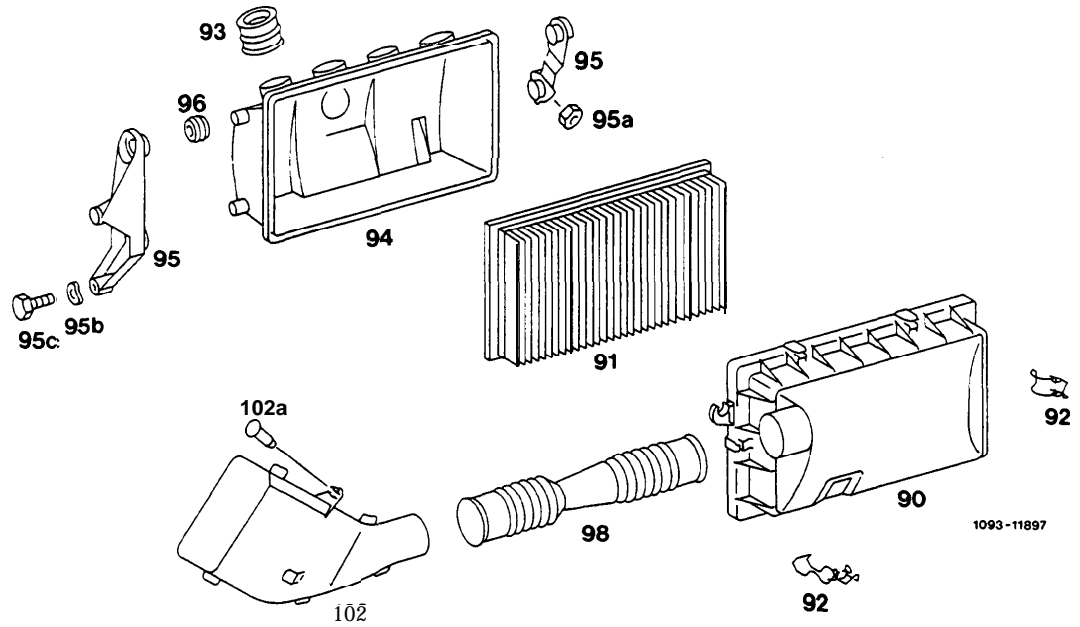

90 Air cleaner cover
91 Air cleaner element
92 Closing clip, 6 each
93 Sealing sleeve, 4 each
94 Air guide housing

95 Holder, 2 each
95a Nut
95b Washer
95c Screw
96 Rubber, 4 each

98 intake line
102 Intake scoop
102a Bolt

B. @California

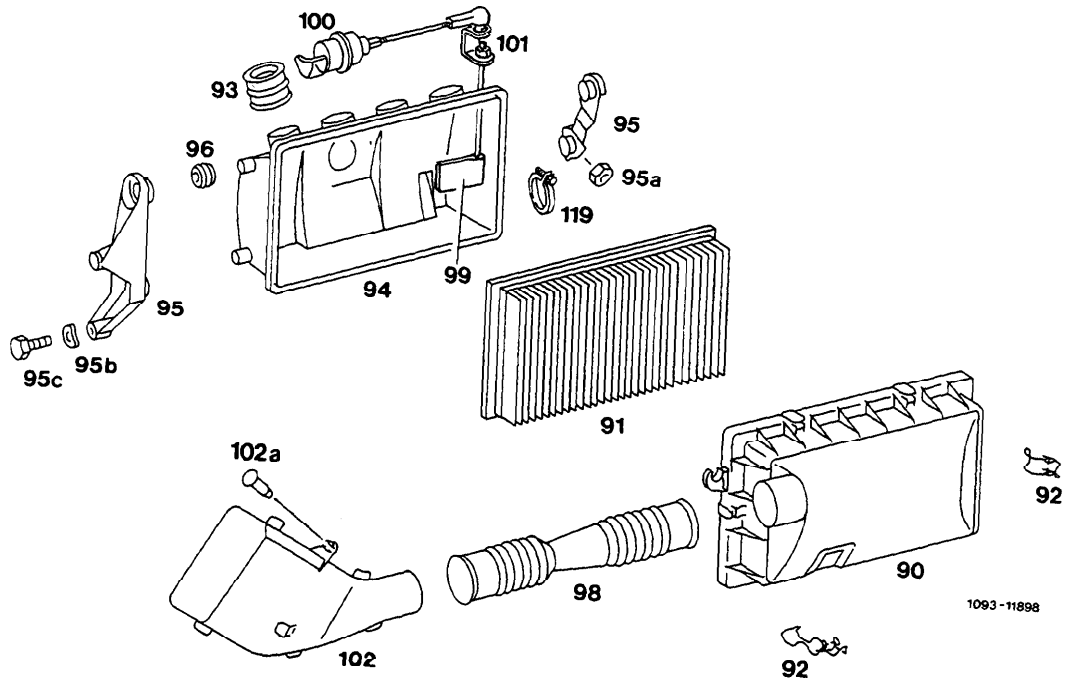

- 90 Air cleaner cover
- 91 Air cleaner element
- 92 Closing clip, 6 each
- 93 Sealing sleeve, 4 each
- 94 Air guide housing

- 95 Holder, 2 each
- 95a Nut
- 95b Washer
- 95c Screw
- 96 Rubber, 4 each
- 98 Intake line
- 99 Pressure control flap

- 100 Vacuum control unit
- 101 Linkage pressure control flap
- 102 Intake scoop
- 102a Bolt
- 119 Clamp