



## 15 Electrical system, engine

---

	Job No.
<b>Preglow system</b>	
Operation of preglow system .....	15-505
A. General .....	
B. Quick-start preglow system .....	
Checking preglow system .....	510
Removal and installation of glow plugs .....	515
<b>Alternator</b>	
Testing alternator with regulator in vehicle .....	600
Renewing fan assembly. ....	642
<b>Starter</b>	
Removal and installation of starter .....	700
B. Engine 601 .....	

#### A. General

On diesel engine combustion proceeds by self-ignition of injected fuel into highly compressed and thereby highly heated combustion air.

In cold engine, the self-ignition temperature is not attained by compression alone. A preglow system is therefore required, which serves the purpose of increasing the temperature of the compressed air, thereby permitting the firing of the cold engine by the ignition (inflammation) of fuel particles on glow plugs.

The duration of preglowing depends on ambient temperature.

#### Design of quick-start pencil element glow plugs

---

The pencil element glow plugs are essentially comprising a housing with screw-in threads M 12 x 1.25 and a heater bar pressed into housing.

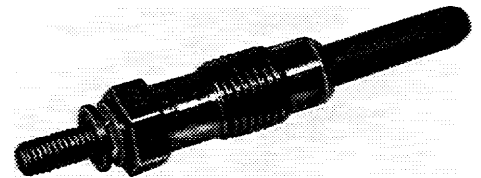

107-14793

The single-pole connecting bolt is screwed to housing by means of a non-releasable round brass nut.

The pencil element glow plugs are designed for a voltage of 11.5 Volts and are operated as a parallel circuit.

The heating element comprises a heating and control winding connected in series:

- 1 Control winding
- 2 Heater winding

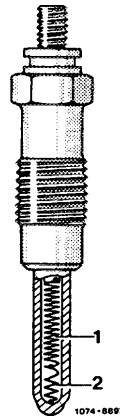

When the glow system is switched on, a current of approx. 30 amps. will flow per glow plug. The heater winding heats the glow plug very fast. The control winding increases its resistance with increasing temperature and limits the current to approx. 8-15 amps. This will protect the glow plug against overload.

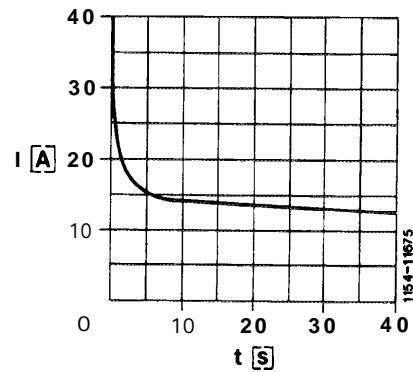

Current curve of quick-start pencil element glow plug

After a glow time of 9 seconds, a heater bar temperature of 900 °C will be attained. After 30 seconds, the max. temperature of 1180 °C.

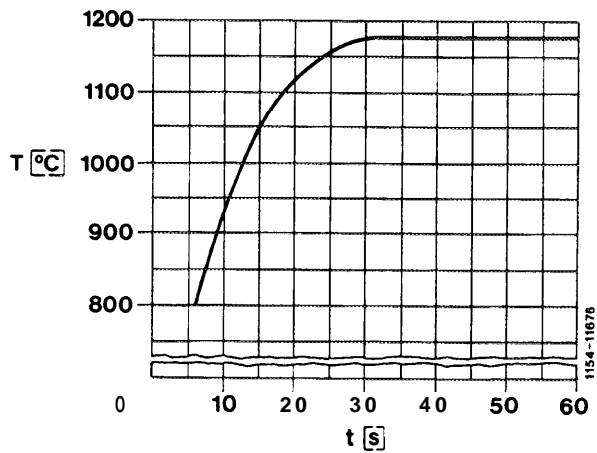

Temperature curve of quick-start pencil element glow plug

## B. Quick-start preglow system

### Note

The essential components of preglow system correspond with those of engines 615 and 616.

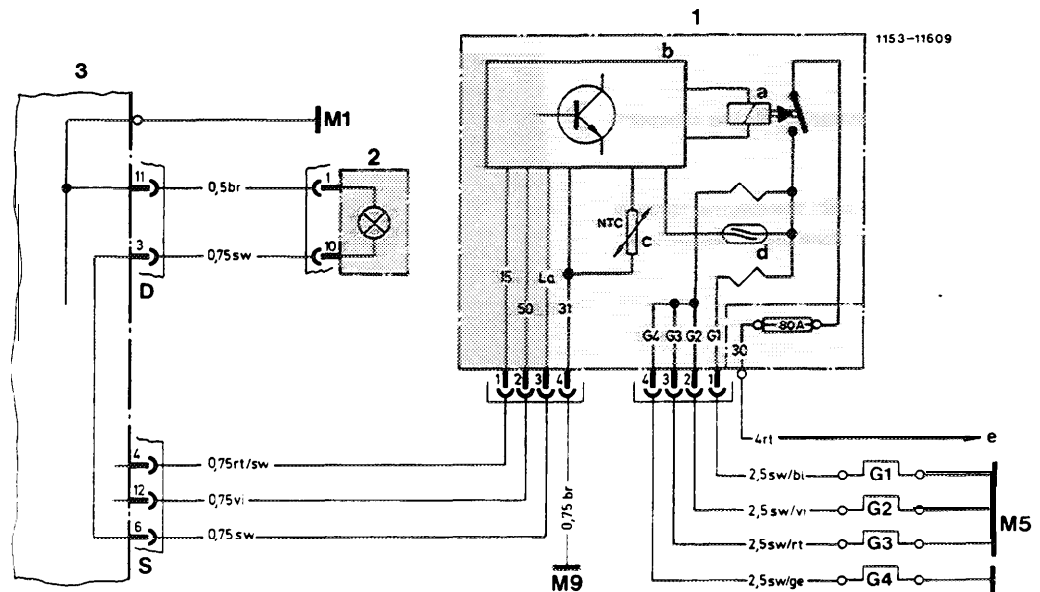

Wiring diagram

- 1 Preglow time relay  
 a Power relay  
 b Electronic unit  
 c Temperature sensor (NTC-resistor)  
 d Reed relay  
 2 Preglow indicator in instrument cluster

- 3 Central electric  
 G1-G4 Pencil element glow plugs  
 M9 Ground, front left (at lamp unit)  
 M5 Ground, engine  
 M1 Main ground behind instrument cluster  
 e Cable connector engine terminal 30

### Quick-start pencil element glow plugs

Quick-start pencil element glow plugs are designed for a voltage of 11.5 Volts and are operated as a parallel circuit.

### Preglow time relay

The preglow time relay is located in engine compartment at wheel house left.

Upon removal of protective cap, the electric connections, as well as the 80 amps. fuse are accessible.

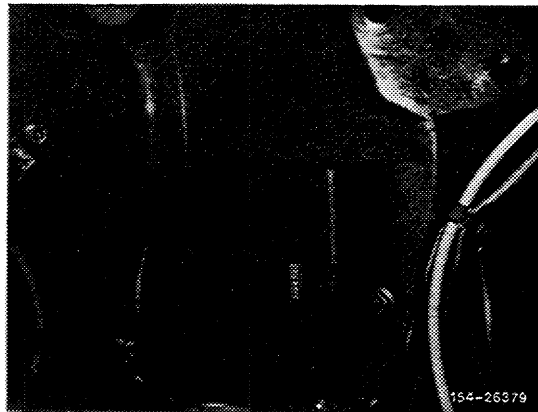

The relay ambient temperature is picked up by way of an NTC-resistor in preglow time relay.

### Functions of preglow time relay

The preglow time relay comprises the following functions:

- Switching of glow current
- Ready-to-start indicator
- Safety shutoff
- Fault indication

**Note:** With unfavorable tolerances of pencil element glow plugs or reed relay (d) it is permissible, that the fault indicator responds only if there are two defective pencil element glow plugs.

The fault indication (monitoring of pencil element glow plugs) proceeds by comparing current of pencil element glow plug G 1 with the current of the remaining pencil element glow plugs G 2-G 4 connected in parallel.

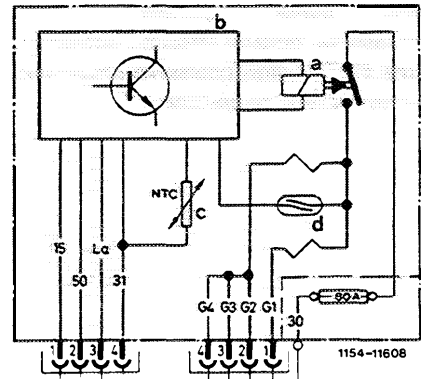

The currents of the two lines to pencil element glow plugs G 1 and G 2 to G 4 are conducted via two oppositely directed reed relay windings with different numbers of windings.

With current flow in both windings of similar size, the magnetic fields are cancelling each other and the reed contact is not responding.

If the balance of the magnetic fields is interrupted by the loss of one or several pencil element glow plugs, the reed contact will close and the electronic circuit (b) is activated.

The preglow check lamp switches off immediately and will therefore not light up when preglowing starts.

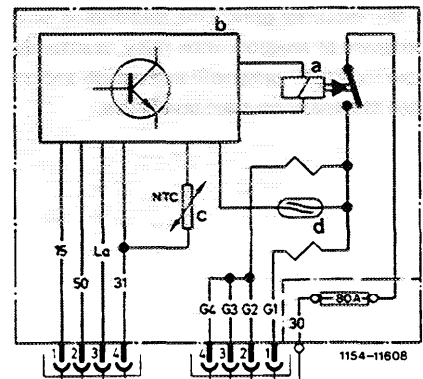

### Switching of glow current

When the key is moved into position "2" (preglow, driving), the preglow relay (voltage on terminal 15) is switched on. The power relay (a) closes the circuit from terminal 30 (positive) via fuse to pencil element glow plugs G 1 -G 4.

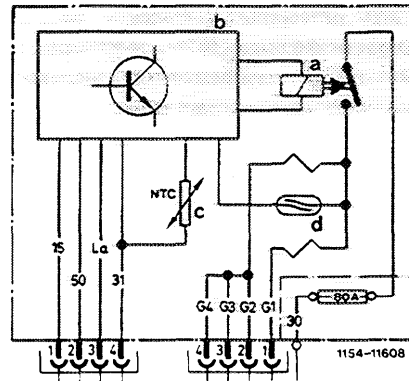

If the key is moved into position "3" (start), the power relay (a) remains attracted, activated by terminal 50. The glow process continues until the key is turned back to position "2".

### Ready-to-start indication

The glow time is determined by means of a temperature sensor installed in preglow time relay.

When the glow system is switched on, the preglow indicator lamp in instrument cluster lights up.

When the required glow time, depending on ambient temperature of preglow time relay, is attained, the preglow indicator lamp will extinguish and thereby indicate the ready-to-start condition.

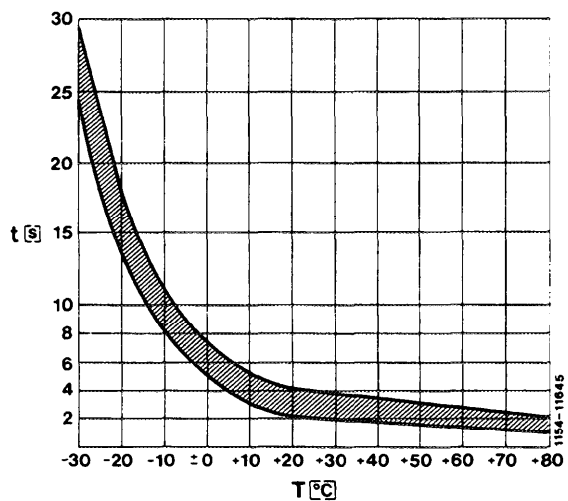

Preglow time



## Safety shutoff

If there is no start following indication of ready-to-start condition within 20-25 seconds, the safety shutoff will interrupt the glow current. If another start follows, the glow system is again switched off for the duration of this starting procedure.

The safety shutoff is no longer fixed and is the result of the time up to ready-to-start condition (preglow indicator lamp extinguishes) plus 20-35 seconds.

a Preglow time  
b Safety shutoff

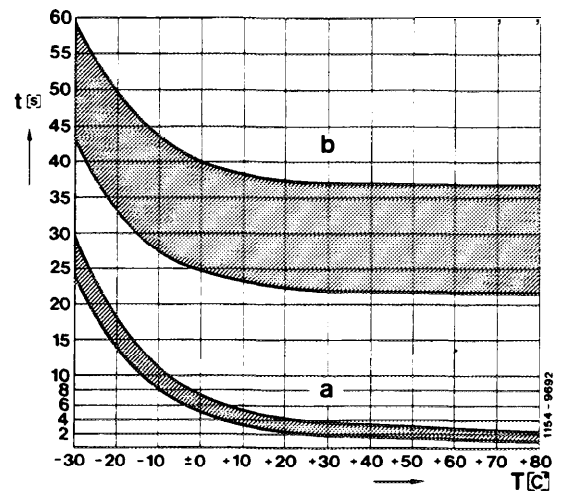

## Fault indication

A fault in preglow system is indicated, when the preglow indicator lamp is not lighting up when the key is moved into position "2".

The following faults are indicated:

- Interruption of line to connection terminal 30.
- Fuse 80 amps. defective.
- Power relay in preglow time relay defective.
- Interruption of one or more lines to pencil element glow plugs.
- Interruption of one or more pencil element glow plugs.

15-510 Checking preglow system

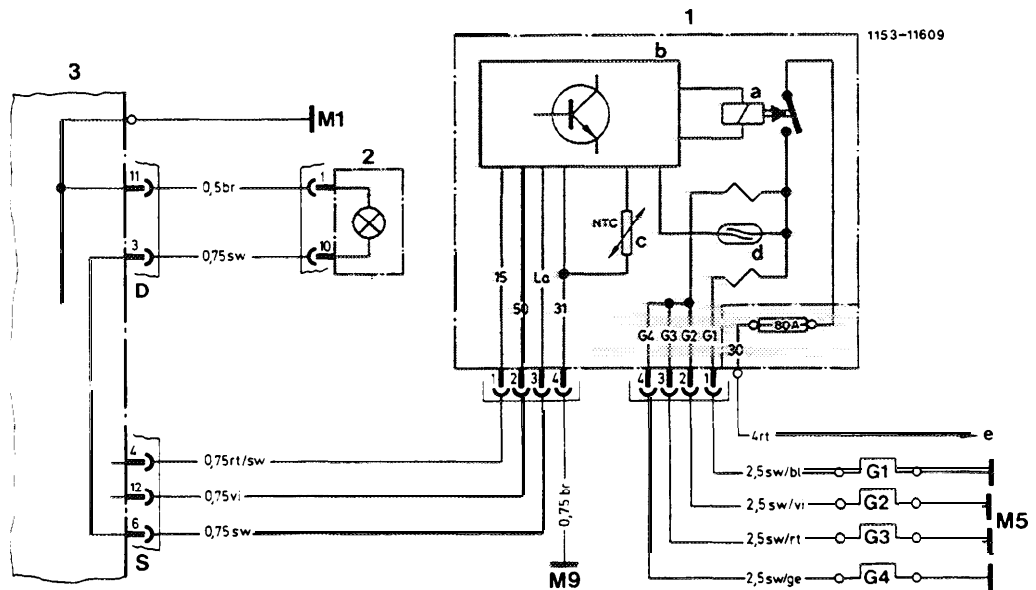

Wiring diagram engine 601 in model 201

- 1 Preglow time relay
- a Power relay
- b Electronic unit
- c Temperature sensor (NTC-resistor)
- d Reed relay
- 2 Preglow indicator in instrument cluster

- 3 Central electrics
- G1—G4 Pencil element glow plugs
- M9 Ground, front left (at lamp unit)
- M5 Ground, engine
- M1 Main ground behind instrument cluster
- e Cable connector engine terminal 30

Testing

1 Testing glow bulb and its line

In the event of a complaint:

Preglow indicator lamp not lighting up when preglow system is switched on, in spite of possible start.

Pull 4-point coupling from preglow time relay, turn key into position "2", bridge jack 1 and 3 of coupling.

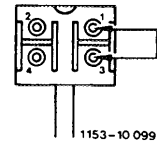

If preglow indicator lamp is not lighting up, test glow bulb and renew, if required.

If glow bulb is in order, test black line from coupling jack 3 of preglow time relay to preglow indicator lamp for interruption. Repair interruption.

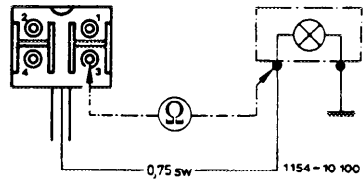

If preglow indicator lamp is lighting up, the preglow time relay is defective, renew preglow time relay.

## 2 Testing main circuit of preglow system for interruption

In the event of a complaint:

Preglow indicator lamp not lighting up, engine cannot be started.

Test voltage on terminal 30 of preglow time relay against ground by means of voltmeter.

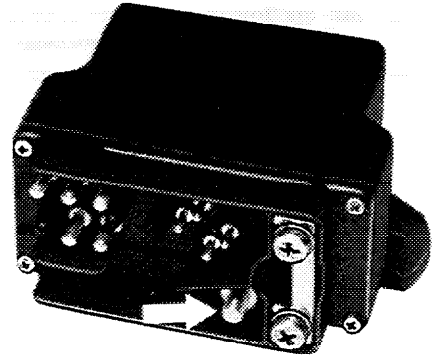

115-20011/1

If there is no voltage, test red line from starter terminal 30 to preglow time relay terminal 30 for interruption and repair interruption, if required.

If voltage is available (approx. 12 Volts), test fuse 80 amps. for tight seat or interruption and renew, if required.

If no fault has been found so far, test voltage on jack 1 of 4-point coupling of preglow time relay against ground.

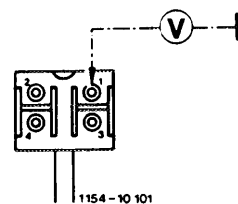

1154-10 101

If there is no voltage with the preglow system switched on, test red/black line from central electrics coupling S jack 4 to coupling jack 1 of preglow time relay for interruption and repair interruption, if required.

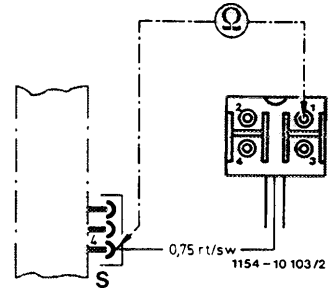

If voltage is available (approx. 12 Volts), connect voltmeter to jack 1 (terminal 15) and jack 4 (terminal 31) and test voltage (should be approx. 12 Volts).

If no voltage is indicated, test brown line from jack 4 to ground for interruption and repair interruption, if required.

If no fault has been found so far, preglow time relay is defective, renew preglow time relay.

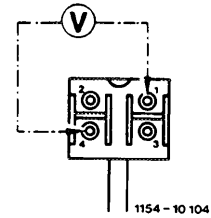

### 3 Testing pencil element glow plugs and their lines

In the event of a complaint:

Preglow indicator lamp not lighting up, engine firing poorly, one or several pencil element glow plugs or the lines to pencil element glow plugs may be interrupted.

In the event of a complaint:

Preglow indicator lamp lighting up, engine fires poorly after attaining ready-to-start condition. An interruption of a pencil element glow plug or a line to pencil element glow plugs of cylinders 2-4, may be responsible, or a wrong power input of pencil element glow plugs in cylinders 1-4.

Measure power input of pencil element glow plugs with DC clip-on.

For this purpose, place clip-on over individual lines on preglow relay.

Cylinder 1 = 2.5 black/blue  
Cylinder 2 = 2.5 black/purple  
Cylinder 3 = 2.5 black/red  
Cylinder 4 = 2.5 black/yellow

Move key in steering lock to position "2". After 10–20 seconds the current input of each glow plug should then amount to 8-15 amps.

If value is higher than 15 amps., renew glow plug.

At a value below 8 amps., test electric line or glow plug with ohmmeter for interruption.

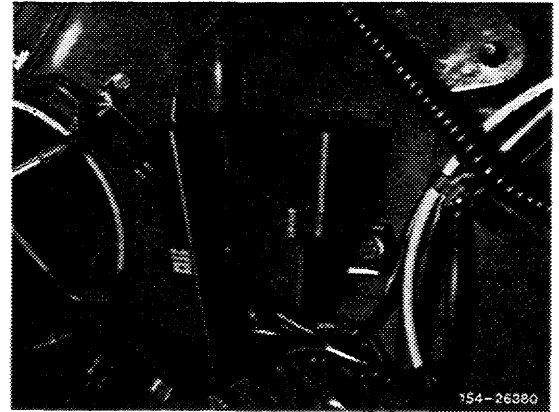

When testing for interruption, pull 6-point coupling from preglow time relay.

Measure resistance against ground (engine block) with ohmmeter connected one after the other to

jack 1 of coupling = pencil element glow plug cylinder 1  
jack 2 of coupling = pencil element glow plug cylinder 2  
jack 3 of coupling = pencil element glow plug cylinder 3  
jack 4 of coupling = pencil element glow plug cylinder 4.

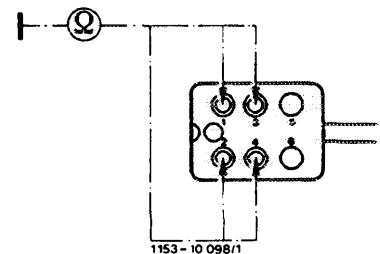

If resistance is measured, the respective pencil element glow plug or the line or connection are interrupted.

Repair interruption in supply line or renew glow plug.

**Note:** It is possible that the indicator lamp (under influence of unfavorable tolerances) indicates a fault only after failure of 2 pencil element glow plugs in cylinders 2-4.

To make sure that the fault indication in preglow time relay is not defective, disconnect in such a case 2 pencil element glow plugs of cylinders 2-4 and repeat preglow procedure.

If the indicator lamp is now indicating a fault (not lighting up), the preglow time relay is in order.

Tightening torques	Nm
Quick-start pencil element glow plugs	20
Electric line on glow plugs	4

---

**Conventional tool**

---

Ratchet 3/8" with universal joint

---

**Removal**

---

1    Unscrew nuts from glow plugs with 3/8" ratchet.

Nuts (1) are undetachably enclosed in cable shoes (2) of harness.

2    Unscrew glow plugs with 3/8" ratchet.

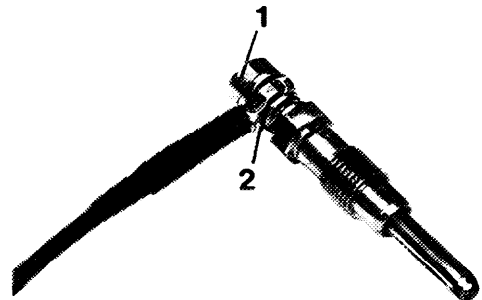

115-26300

**Installation**

---

3    For installation proceed vice versa.

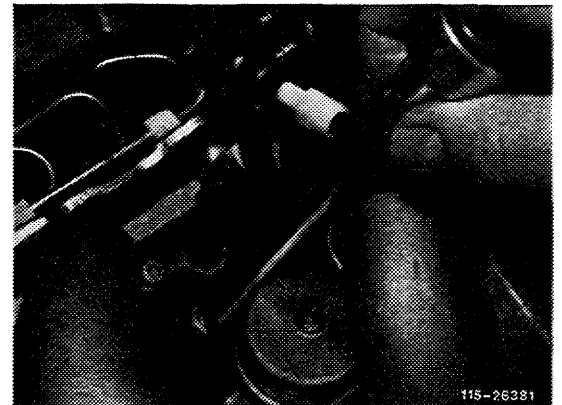

115-26381



## 15-600 Testing alternator with regulator in vehicle

### Test values

#### Regulating voltage — regulator

Regulating voltage (on battery) Volts (nominal value)	Engine speed 1/min	Battery load Compulsory consumers only (e.g. ignition)	Battery acid density kg/dm <sup>3 1</sup> )	Regulating voltage measured after
13.0–14.5	3000		normal min. 1.24 tropics min. 1.19	approx. 2 minutes

<sup>1)</sup> If battery state of charge is less than 1.24 kg/dm<sup>3</sup> or 1.19 kg/dm<sup>3</sup>, the regulator will not operate in regulation range during test, but will fully excite alternator, that is, a defective regulator with continuous full excitation will not be recognized.

#### Charging current of alternator

Engine	Alternator nominal output at 14V amps	Alternator speed 1/min	Engine speed 1/min	Charging current amps	Ratio engine-alternator
102	55	2000 6000	850 2550	36 55	2.35
102 (USA)	65	2100 6000	890 2550	43 65	2.35
601	55	2000 6000	790 2370	36 55	2.53

Note: When testing charging current at 6000/min of alternator, the voltage should not drop below 12.7 volts.

#### With engine stopped

1 Check battery and alternator connections, as well as grounding strap between engine and body for tight seat and perfect condition. In addition, check V-belt tension and pay attention to charge indicator lamp (required: ignition on = charge indicator lamp on; ignition off = charge indicator lamp off).

2 As a prerequisite for measuring regulating voltage, check acid density of battery in all cells.

Required values: normal min. 1.24 kg/dm<sup>3</sup>  
tropics min. 1.19 kg/dm<sup>3</sup>

3 If discharge is suspected, test battery discharge current (all consumers switched off, pay attention to time clock and consumers with rest potential input).

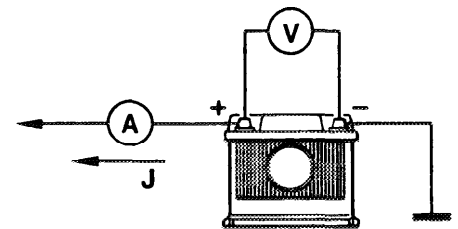

1154 - 8817

With engine running

4 Pay attention to charge indicator lamp at idle and at increasing engine speed (up to approx. 3000/min) — light should go out.

5 Check regulating voltage. Acid density of battery should amount to at least  $1.24 \text{ kg/dm}^3$  or tropics  $1.19 \text{ kg/dm}^3$ . Run engine at 3000/min. Load battery with compulsory consumers only (e.g. ignition). Read regulating voltage after approx. 2 minutes of operation.

Nominal value 13.0-14.5 volts.

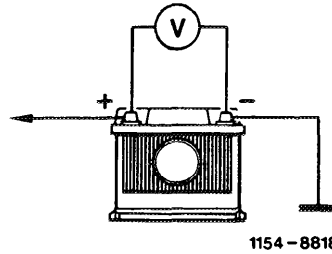

### 6 Testing charging current

a) with ammeter

Run engine at idle to respective alternator speeds (refer to Table).

Load battery with installed consumers or with load resistance until max. charging current is attained. Regulating voltage should not drop below 12.7 volts

Note: If measuring proceeds according to connection diagram on battery, the previously supplied current for compulsory consumers, e.g. ignition, fuel pump, must be added to the battery current measured.

When using DC clip-on, the entire charging current can be measured on alternator.

$J_B$  Battery current  
 $J_G$  Alternator current  
 $J_V$  Consumer current

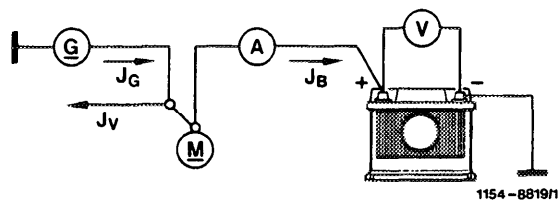

b) Diode test (harmony)

Evaluate harmony of regulating voltage (voltage flow) (measuring value or good/poor evaluation with oscilloscope). For this purpose, load battery with high beam at engine speed of 3000/min.

Alternator in order (voltage peaks possible — but without significance).

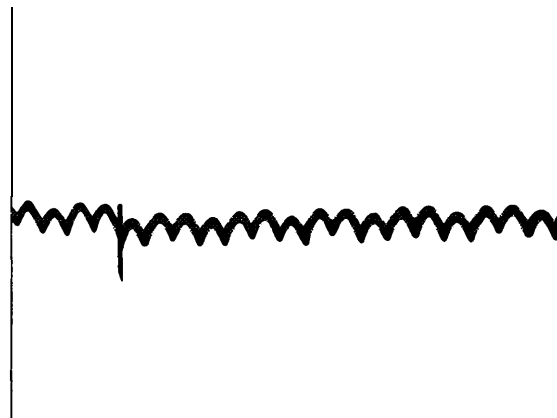

Alternator defective (example)

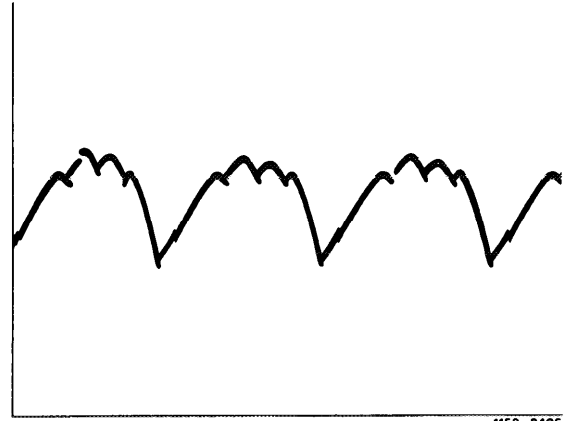

1153-8406

## 15-642 Renewing fan assembly

### Tightening torques

	Nm
Fastening nuts of fan assembly with divided pulley	35-45
Fastening nut of fan assembly with taper rib pulley	50 + 5

### Note

The fan disk is subject to considerably varying stresses. The extent of these stresses depends mainly on driving conditions. This is why, when reconditioning or exchanging alternators after driving for more than 100000 km, the fan assembly will also be replaced.

### With divided pulley

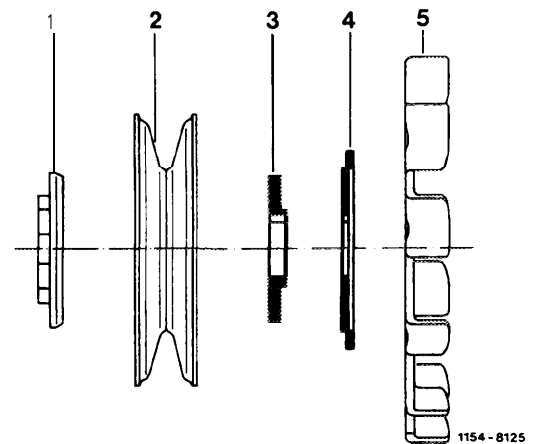

- 1 Front groove disk
- 2 2-piece pulley
- 3 Rear groove disk
- 4 Supporting disk
- 5 Fan disk

### With taper rib pulley

Holder, part no. 126 589 00 40 00 can be used for holding pulley, if fitted with a segment from taper rib pulley.

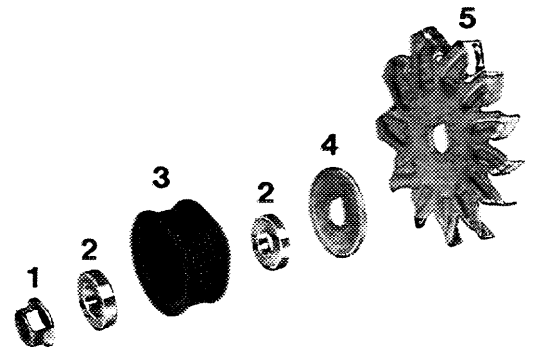

- 1 Flange nut
- 2 Spacing washer
- 3 Taper rib pulley
- 4 Supporting disk
- 5 Fan disk

115-26506

## B. Engine 601

### Removal

---

- 1 Disconnect negative terminal of battery.
- 2 Completely remove air cleaner (09-400).
- 3 Disconnect electric lines terminal 30 and terminal 50 on starter.

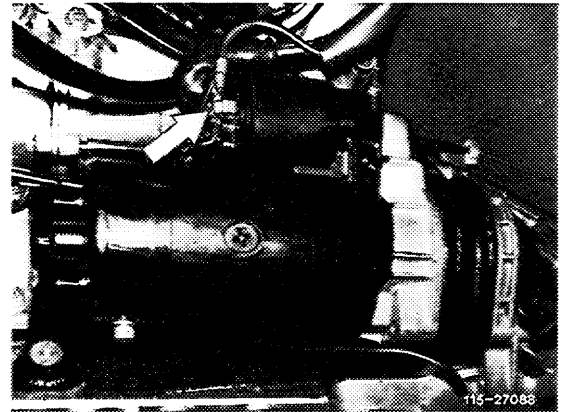
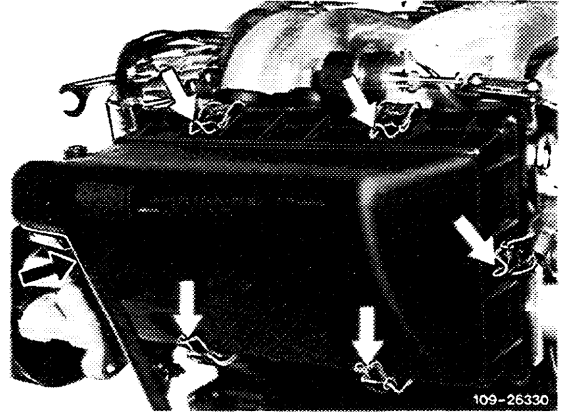

- 4 Remove noise capsule rear (2).

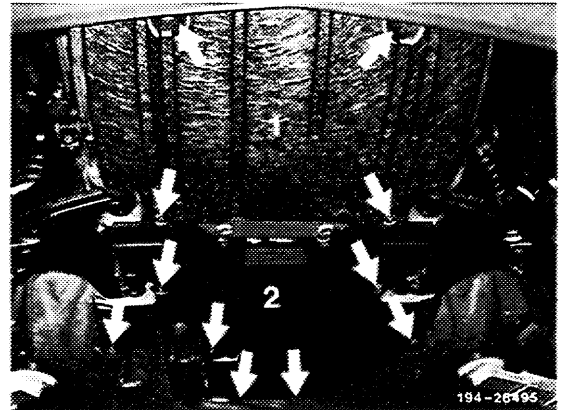

- 5 Unscrew fastening screws of starter on transmission and remove starter in upward direction.

### Installation

---

for installation proceed vice versa.

