

A. Testing battery

Visual checkup		for external leaks	
<p>Checking acid level. If the battery level must be corrected by adding distilled water, recharge battery afterwards up to gassing.</p>		<p>should reach up to mark. On batteries on which the fluid level cannot be seen, keep adding distilled water until water is no longer flowing off at overfill guard.</p>	
Battery state of charge	Climatic conditions	Density at 20 °C (kg/dm ³)	Procedure
charged	normal	1.28*	–
	tropics	1.23*	
half-charged	normal	1.20	recharging required
	tropics	1.16	
discharged	normal	1.12	recharge immediately
	tropics	1.08	

*) Tolerance ± 0.01 kg/dm³

Test acid density in individual cells
Acid density should be the same in all cells

Example for defective batteries

a) Acid density in one cell deviates noticeably in downward direction.

–	1	2	3	4	5	6
	1,28	1,28	1,28	1,28	1,16	1,28

Condition: Short-circuit in cell 5

b) Acid density deviates in two adjacent cells (e. g. 2 and 3) clearly from remaining measuring values in downward direction.

–	1	2	3	4	5	6
	1,28	1,16	1,16	1,28	1,28	1,28

Condition: Leak in cell wall between cell 2 and 3.

The leaking cell wall and the connector operate as a conductor through which the cells are discharged.

Testing battery under load

(perform only if no fault has been found during previous tests)

This test is possible only at uniform acid density of cells and an acid density of at least 1.24 kg/dm³.

Capacity	Ah	44	55	66	88	90
Load current (approx. 3 times capacity)	A	135	165	200	265	270
Minimum voltage ¹⁾ after 10 s at acid density	V	9		10		
	kg/dm ³	1.24		1.28		

¹⁾ The test voltage should attain a constant value after 10 seconds. Slight deviations have no influence. If the voltage drops considerably or collapses, the battery is defective.

B. Charging the battery

Batteries can be charged with DC only. For charging, the battery is separated from electric circuit of vehicle and connected to a charger:

Positive pole (+) of battery to positive pole of charger,
negative pole (-) of battery to negative pole of charger.

The loading current (A) should amount to 10% of battery capacity, e. g. at 55 Ah a charging current of 5.5 A.
For recharging, higher currents may be employed up to start of gassing (2.4 V / cell).

Charge until acid density and charging voltage are no longer increasing within 2 hours. Note that the measuring value of the acid density changes by 0.01 per 15 °C temperature difference. If, for example, an acid temperature of 34 °C is measured, the simultaneously measured acid density should be higher by 0.01 to obtain the value referenced to 20 °C.

C. Handling battery when laying-up vehicle

Prerequisite: Battery state of charge in order

Acid density min. 1.26 kg/dm³ (tropics 1.21 kg/dm³)

- 1 Disconnect negative terminal of battery.

This will prevent discharging by rest potential consumers or time clock.

- 2 Recharge battery after 3 months. (Acid density 1.28 kg/dm³, tropics 1.23 kg/dm³).

Attention!

Never leave battery standing about in discharged condition, since otherwise the plates will sulfate. Sulfated plates will cause initial damage to battery and will lead to early breakdown.

Antifreeze in charged condition

		normal	tropics
charged		- 65	- 40
half-charged	in °C	- 30	- 13
discharged		- 12	- 6

D. Batteries with overfill protection

These batteries are provided with rubber diaphragm elements and vent ducts in filler neck of battery cover. This will prevent an increase of fluid level above "max" mark when the batteries are filled.

When refilling with distilled water, make sure that the diaphragm is not punched through or removed. Also make sure that on batteries with overfill protection no cell closing plug of former batteries (without overfill protection) is used. This type of cell closing plug has a vent bore at the top in cover.

Checking fluid level and adding distilled water

On batteries with overfill protection the fluid level is determined by means of the marks on outside of battery.

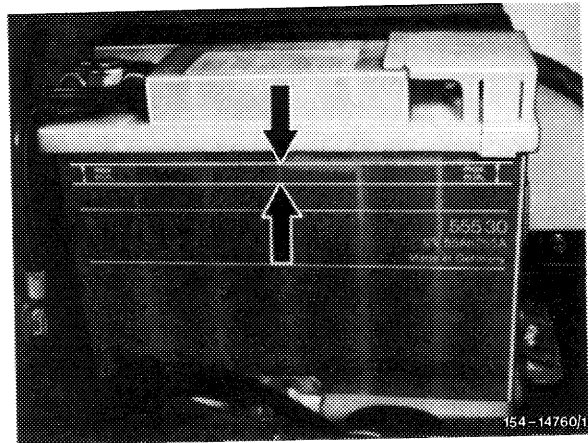

Refilling with distilled water

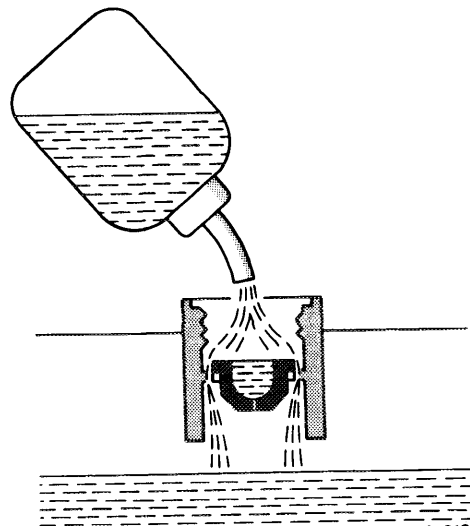

The distilled water flows through circularly located slots (4) into cell. The air displaced from cell flows through 4 vent bores (3) into the open air.

- 3 Vent bores
- 4 Filling-in slots
- 5 Diaphragm

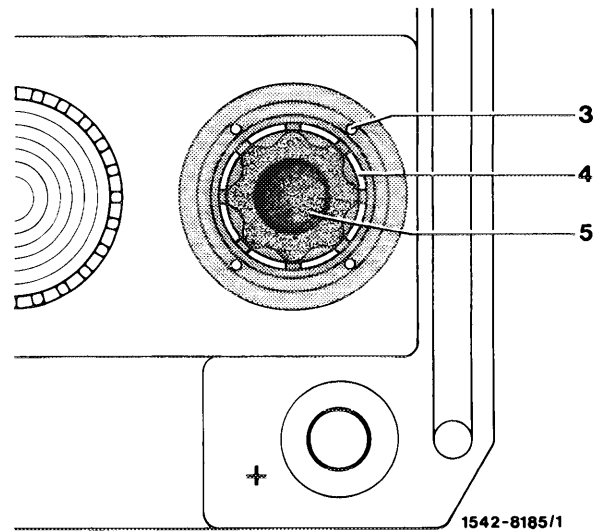

When the fluid level is at "max" mark it will simultaneously close the vent ducts. As a result, the air can no longer escape and an air cushion (2) is established in cell. This air cushion prevents that additional fluid can flow into cell from filler chamber. The battery is filled up to max. capacity.

- 1 Vent duct
- 2 Air cushion

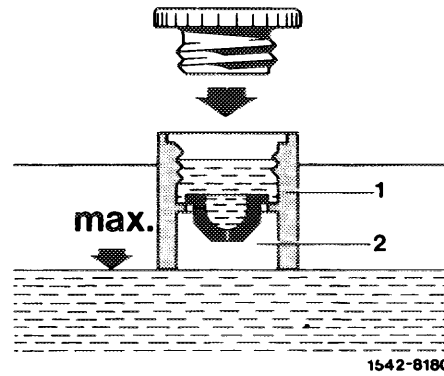

Checking acid density

To check acid density, insert syphon through triple-slotted diaphragm and remove required quantity of fluid. Upon removal of syphon, the diaphragm will again be watertight.

a = max. 9 mm

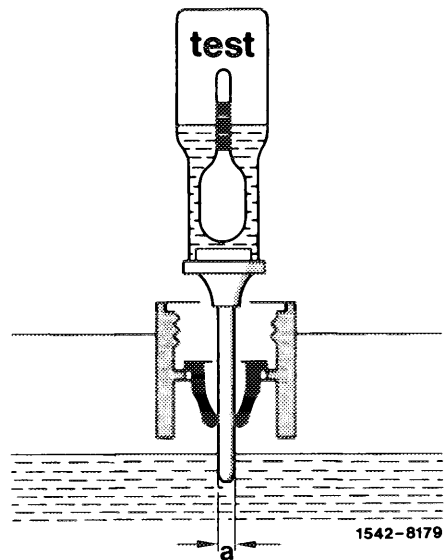

Initial filling of battery with acid

During initial filling with acid insert the filling device or a conventional funnel through diaphragm and fill battery up to "min" mark.

a = max. 9 mm

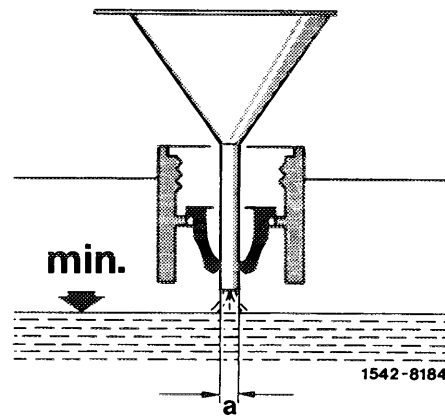
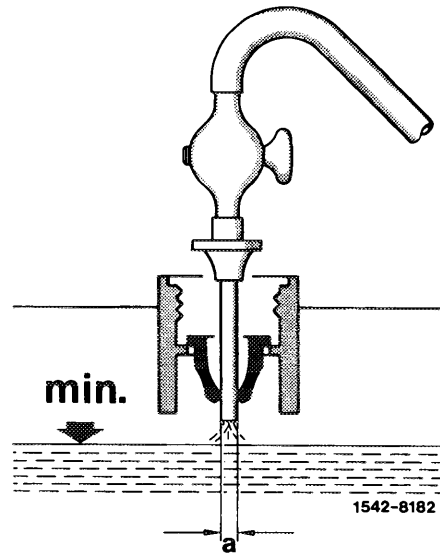

Continue filling-in acid up to "max" mark through slots with diaphragm closed.

Note: If a battery with overfill protection is scrapped, remove rubber diaphragms for emptying.

