

Data

Engine	116.96	117.96
Height „A” of the crankcase when new	216.35–216.45	245.35–245.45
Minimum height of the necessary material removal ¹⁾	216.20	245.20
Permissible deviation from the parallel of the upper mating surfaces to the crankshaft center	in longitudinal direction	0.08
	in transverse direction	0.05
Permissible deviation from evenness of the upper mating surfaces		0.02
Mean roughness (Rz) of the upper mating surfaces		0.006–0.016
Test pressure: water jacket with air under water in bar		3
Distance from piston crown to crankcase mating surface		see 03–316
Cylinder bore chamfer		see Note

¹⁾ The total material removed from crankcase and cylinder head of an engine may not exceed 0.5 mm (see 01--418).

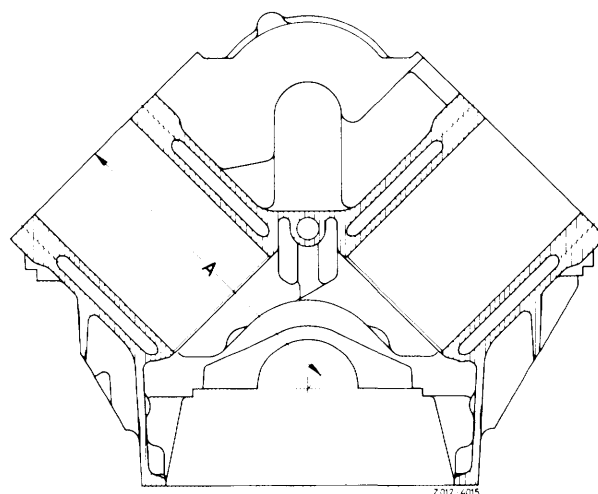

Note

After facing the surfaces, chamfer the cylinder bores. Smooth out the lower edge of the chamfer with a polishing stone.

If the crankcase mating surface was remachined, the valve timing has to be adjusted again (05–215).

