

05-320 Replacing timing chain

Tightening torques

Nm

Mounting bolt for camshaft sprocket

100

Bolts for cylinder head cover

3

Special tools

Spring compressor for valve spring

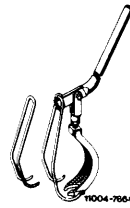

123 589 03 61 00

Socket insert 27 mm, 1/2" drive
for rotating the engine

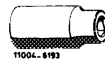

001 589 65 09 00

1/2" drive insert, 80 mm long,
for rotating the engine

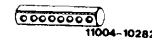

617 589 00 16 00

Note

A repair chain with connecting link is available for repairs.

If only an endless timing chain is available, the chain can be opened prior to installation by grinding off **both pins of a link** and subsequent installation by means of a connecting link.

The endless timing chain is installed with timing case cover removed. Check sprockets for score marks and pitting.

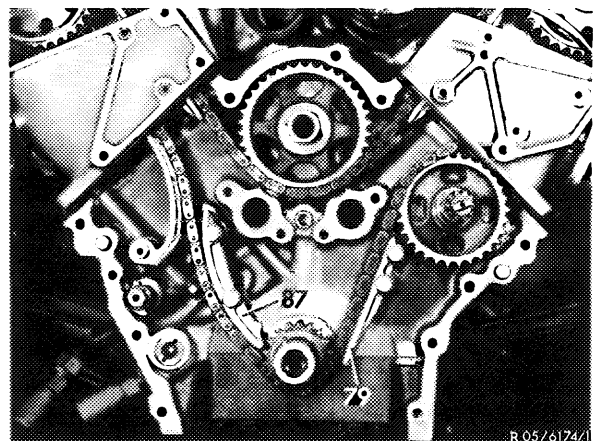

R 05/0174/1

Repair duplex chain with connecting link.

Engine 116.960/961/962/963/964/965

186 links

Engine 117.960/961/962/963/964/965/967/968

198 links

The simplex chain (in **J** and **USA** engines 116.96 up to model year 1983) must be replaced with the duplex chain together with all sprockets in the case of repair. The left-hand cylinder head must be removed for this purpose.

Replacement

- 1 Remove spark plugs.
- 2 Remove rocker arm on right-hand camshaft (05–230).

Caution!

The rocker arms must be installed in the same position from which they were removed.

- 3 Remove chain tensioner (05–310).

- 4 Cover chain box with rag and cut timing chain by means of chain cutting tool or grind off both pins of one link.

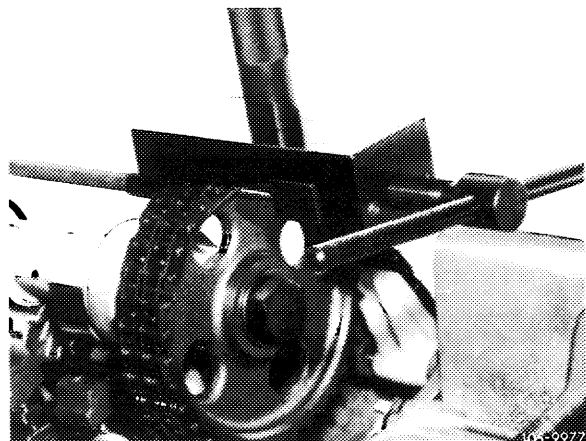

5 Attach new timing chain to old timing chain by means of a connecting link while removing cut-up connecting link.

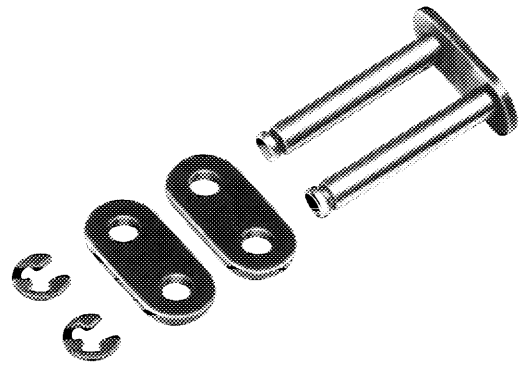

105-9259

6 Slowly rotate the crankshaft by means of tool combination in the direction of rotation of engine while simultaneously pulling up the old chain until the connecting link comes to rest against the uppermost position of the right-hand camshaft sprocket.

Caution!

While rotating the crankshaft, the timing chain should always remain in mesh with both camshaft sprockets.

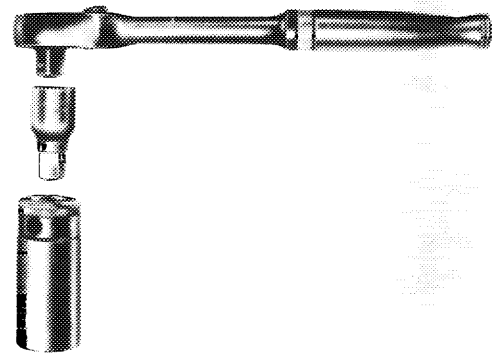

R100-5952

7 Disconnect old timing chain and connect new timing chain by means of a connecting link.

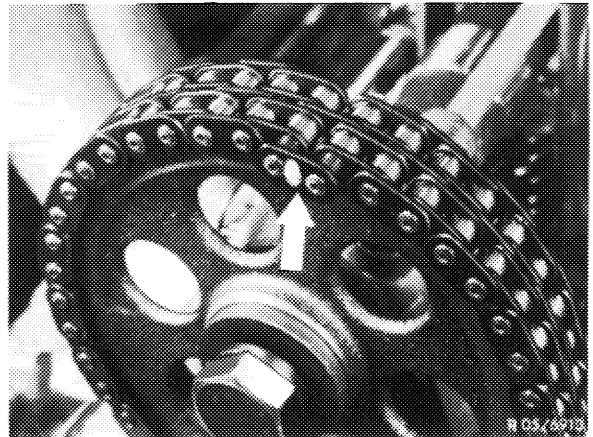

R 03-6913

8 Set engine to ignition TDC at No. 1 cylinder.

If the markings (arrow) are not accurately lined up, check timing (05-215).

9 Complete the engine.

Note: Remove all metal deposits from worn-out sprockets and timing chains in the engine. Renew oil filter element and engine oil.

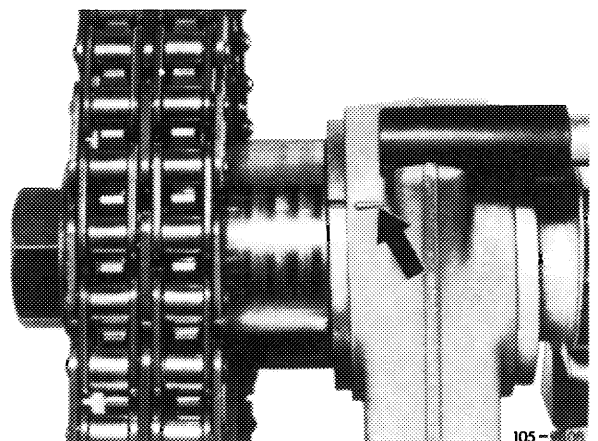

105-9259