

03-316 Removal and installation of pistons

Association piston-cylinder

Group No.				0	1	2		
Standard dimension Std				piston dia.	91.98	91.99	92.00	
				cylinder dia.	92.00	92.01	92.02	
1st repair stage + 0.5				piston dia.	92.48	92.49	92.50	
				cylinder dia.	92.50	92.51	92.52	
2nd repair stage + 1.0				piston dia.	92.98	92.99	93.00	
				cylinder dia.	93.00	93.01	93.02	

Engine	Piston code No.			Piston crown refer to illustration	Spacing between piston crown and parting surface of cylinder crankcase		Compression ε : 1
	Std	+ 0.5	+ 1.0		Std	+ 0.5 and + 0.1	
116.980							
116.981	51	52	53	cavity 1 mm deep d = 52 mm	projection max. 0.75 min. 0.30	projection max. 0.10 recess max. 0.35	9.3
116.982							
116.983	54	55	56	2 valve niches			9.5
116.980 (USA)							
116.981 (USA)							
116.984	66	67	68	without cavity 4 valve niches	projection max. 0.75 min. 0.6	projection max. 0.55 min. 0.1	9
116.985	69	70	71				
116.990 NV				cavity 4 mm deep 56 x 84 mm oval without valve niches	projection max. 0.85 min. 0.30	projection max. 0.40 min. 0.10	8
116.991 NV	57	58	59				
116.992 NV	60	61	62				
116.993 NV							
116.984 NV				cavity 5.1 mm deep d = 66 mm 4 valve niches	projection max. 1.05 min. 0.6	projection max. 1.05 min. 0.6	7.5
116.985 NV	72	73	74				
117.982	19	20	21	cavity 5.9 mm deep d = 66 mm 2 valve niches	projection max. 0.75 min. 0.30	projection max. 0.25 recess max. 0.20	8.8
117.983	25	26	27				
117.985	31	32	33	cavity 5.9 mm deep d = 66 mm 4 valve niches	projection max. 0.75 min. 0.30	projection max. 0.25 recess max. 0.20	8.8
117.986	37	38	39				
117.981 (USA)				without cavity without valve niches	recess max. 3.60 min. 3.15	recess max. 4.1 min. 3.65	8.0
117.982 (USA)	10	11	12				
117.983 (USA)	13	14	15				
117.984 (USA)							
117.985	40	41	42	cavity 8.8 mm deep d = 66 mm 4 valve niches	projection max. 0.75 min. 0.30	projection max. 0.25 recess max. 0.20	8.0
(AUS) (J) (S) (USA)	50 ¹⁾	51	52				
117.986	53	54	55				
(AUS) (J) (S) (USA)	56	57	58				
117.986	60	61	62				
117.992 NV				cavity 9 mm deep d = 80 mm 4 valve niches	projection max. 0.75 min. 0.30	projection max. 0.25 recess max. 0.20	7.5
117.993 NV	22 ²⁾	23	24				
117.985 NV	43 ³⁾	44	45				
117.986 NV							

¹⁾ Piston with reduced friction capacity (oil ring 008 037 30 18) for (USA) entering production 1979 starting engine No. 117.985-12-043649 and 117.986-12-049507.

²⁾ 2 valve niches.

³⁾ 117.985 NV starting engine end No. 009 551, 117.986 NV starting engine end No. 013 041.

Test values		when new	wear limit	
Piston clearance		0.02–0.03	0.08	
Max. wear limit of cylinder bores in driving or transverse direction at upper reversing point of 1st piston ring		0.10		
Weight difference of pistons in one engine		4 g	10 g	
Piston pin dia.		25.99 to 26.00		
Piston pin clearance in connecting rod bushing		0.007 to 0.018		
Piston pin clearance in piston		0.002 to 0.012		
Gap clearance of piston rings	groove 1	engine 116 engine 117	0.30 to 0.45 0.35 to 0.55	1.0
	groove 2		0.35 to 0.55	0.8
	groove 3		0.25 to 0.40	0.8
Side clearance of piston rings	groove 1	engine 116 engine 117	0.05 to 0.8 0.06 to 0.9	0.15
	groove 2		0.04 to 0.07	0.08
	groove 3		0.03 to 0.06	0.08

Tightening torque

Connecting rod nuts	initial torque	40–50 Nm
	angle of rotation torque	90–100°

Special tools

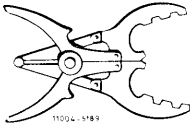
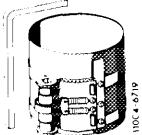
Expanding pliers for piston rings		000 589 51 37 00
Clamping strap for piston rings		000 589 04 14 00

Note

Standard pistons are subdivided in three tolerance groups (group numbers). They are punched into piston crown as follows:

1. Piston dia. e. g. 92.00
2. Piston code number e. g. 72
3. Group number e. g. 2
4. Direction indicating arrow

a Valve depression
b Cavity dia.

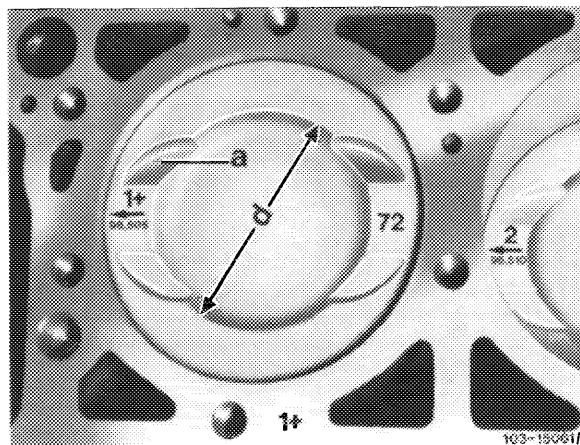

The group number is also punched into cylinder crankcase parting surface.

The group number of pistons (e.g. 2) must be in accord with group number of cylinder bores (series production).

The specified piston clearance will then be maintained.

In the event of repairs, hone all cylinder bores to dimensions of existing pistons plus piston clearance (refer to table).

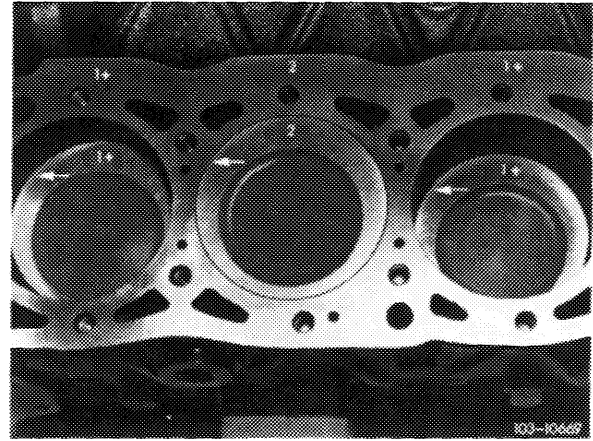

Removal

- 1 Remove connecting rod with piston in upward direction.
- 2 Remove piston pin lock and force out piston pin.
- 3 Recondition and square connecting rod (03-313).

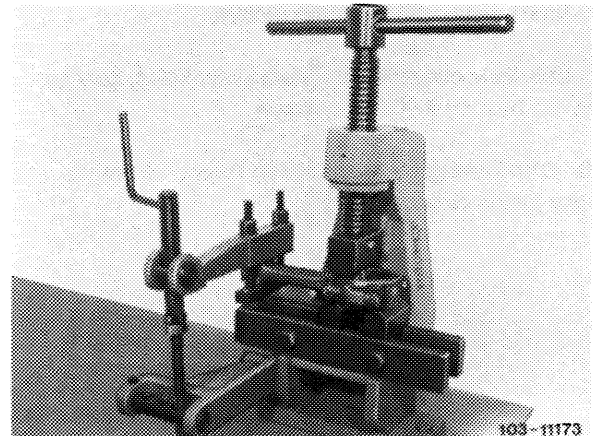

Installation

- 4 Check piston rings of used pistons for gap and end clearance.
- 5 Lubricate piston pins and connecting rod bushings.



- 6 Mount pistons on connecting rod in such a manner that the arrow points in driving direction and the locking grooves (3) in connecting rod to outer sides of engine.

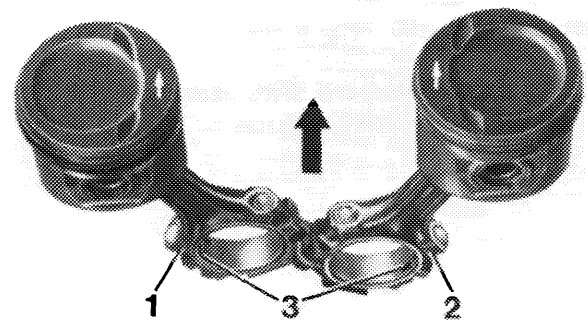

- 1 Connecting rod thrust end
- 3 Locking grooves

7 Push-in piston pin manually.

Attention!

Do not heat piston.

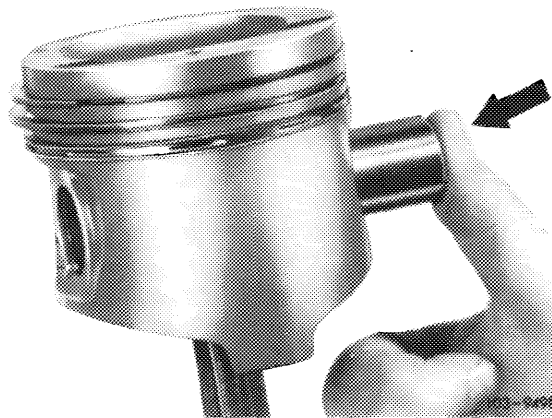

8 Insert piston pin lock into groove.

9 Lubricate clean cylinder bores, crankpins, connecting rod bearing shells and pistons.

10 Distribute gap ends of piston rings uniformly along piston circumference.

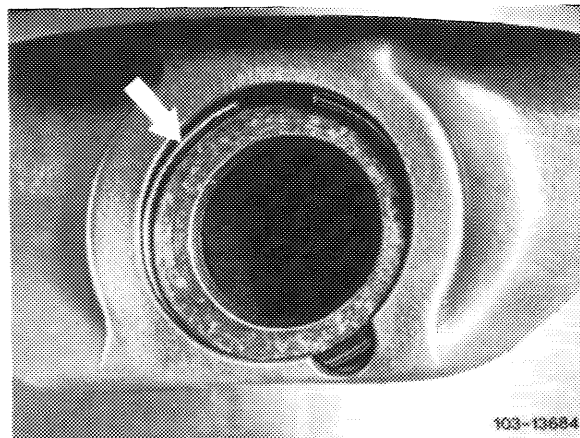

11 Mount clamping strap for piston rings and introduce piston with arrow in driving direction.

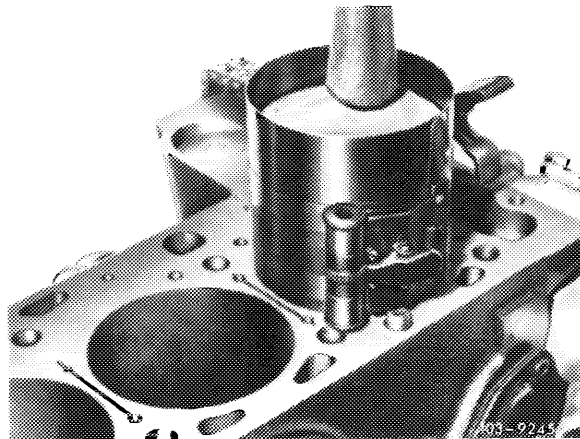

12 Position connecting rod bearing cap with code numbers in relation to each other on connecting rod and tighten connecting rod nuts to 40–50 Nm initial torque and 90–100° angle of rotation torque.

13 Rotate crankshaft and check clearance between piston pin eye and connecting rod.

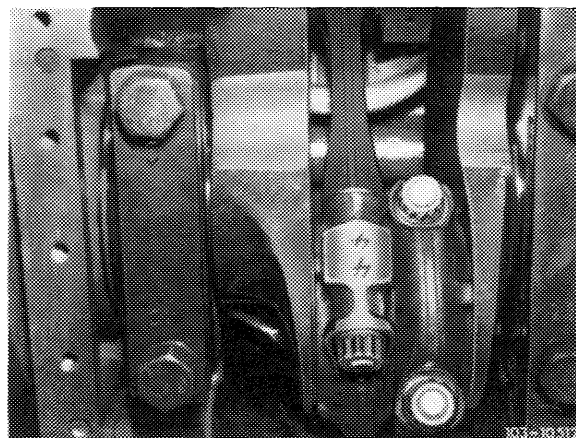

14 In TDC position of pistons, measure distance between piston crown and cylinder crankcase parting surface (refer to table).

