

07.3–210 Reconditioning system pressure regulator and pressure compensating valve

Test data

System pressure (engine cold or warm) at idle

5.0–5.6 bar gauge pressure

Note

O-ring (1) and contour ring (1) of control piston (2) are available as individual components.

Reconditioning

1 Reduce fuel pressure. For this purpose, unscrew fuel return hose (arrow) on fuel distributor. Catch fuel with a rag. Close fuel return hose blind.

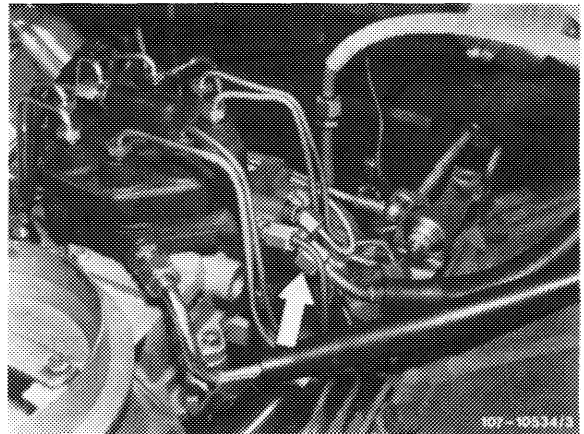

System pressure regulator

2 Unscrew closing plug (10). When screwing out, make sure that the compression spring (3) and the adjusting washers (4) are not dropping out.

3 Remove control piston (2) with a magnet or a wooden stick (pencil).

Remove O-ring (1) on 1st version.

1st version

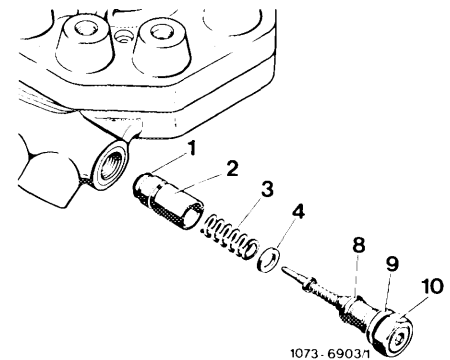

4 On 2nd version, cut through contour ring (1) of control piston and remove.

2nd version

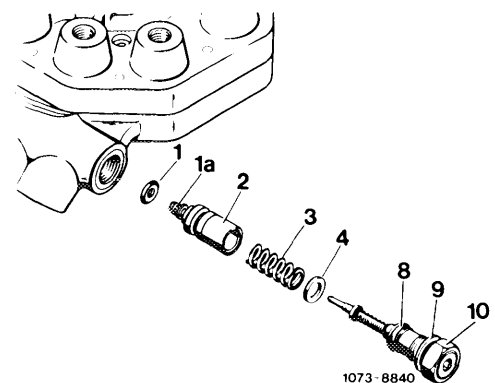

5 Install components from repair kit.

Attention!

The control piston (2) is fitted into fuel distributor and should not be replaced. If required, renew complete fuel distributor.

On 2nd version, carefully slide new contour ring (1) over lock (1a), lubricate slightly and mount control piston with compression spring (3).

Mount assembly group with removed adjusting washers (4) and supplied copper sealing ring (9).

6 Check system pressure (07.3–120). If the system pressure deviates from nominal value, remove system pressure regulator once again and adjust system pressure by adding or removing adjusting washers (4).

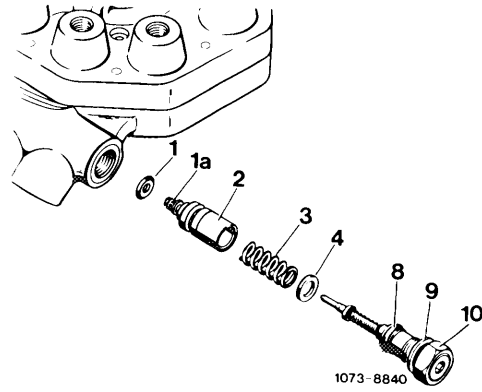

The adjusting washers are contained in repair set and are available at the following thickness:

- 0.1 mm
- 0.15 mm
- 0.3 mm
- 0.4 mm
- 0.5 mm

0.1 mm provides approx. 0.2 bar system gauge pressure.

Pressure compensating valve

7 Unscrew closing plug (1). Remove piston (2) with contour ring (3).

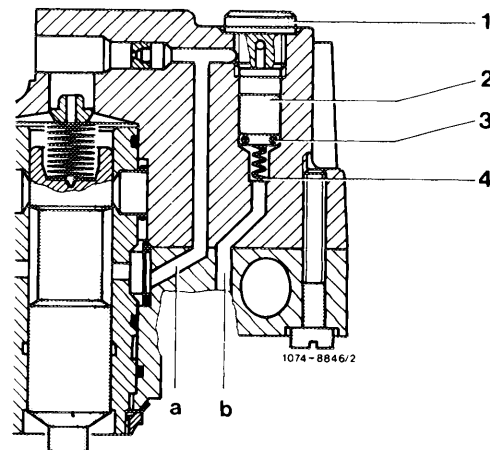

8 Install components of repair set.

To loosen closing plug (1), use screwdriver element,
e.g. Hazet, D-5630 Remscheid, order No. 992-T 30.

