

Removal

- 1 Disconnect battery.
- 2 Partially drain coolant.
- 3 Remove air filter.
- 4 Disconnect regulating linkage and remove longitudinal regulating shaft (07.4—310).
- 5 Pull-off cable plug connections.
- 6 Loosen fuel hoses on pressure regulator and on cold starting valve.
- 7 Unscrew fastening nuts of injection valves and put injection valves aside.
- 8 Unscrew the 16 fastening screws of intake pipe.
- 9 Loosen hose clip on thermostat.
- 10 Lift intake pipe and splash wall and remove toward the rear.
- 11 Clean intake pipe and check flange surfaces with straightedge and finish on surface plate, if required.

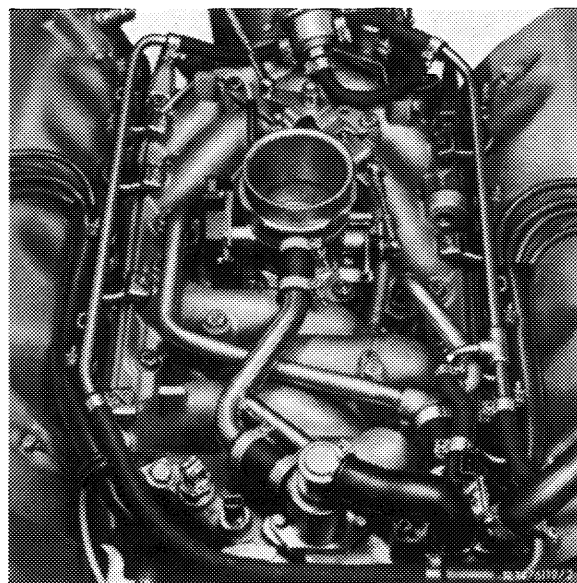

Installation

- 12 Mount intake pipe in vice versa sequence using new gaskets.
- 13 Adjust regulating linkage (07.4—300).
- 14 Connect battery.
- 15 Add coolant.
- 16 Run engine, test intake system for leaks by spraying with Iso-Oktan DIN 51756 or benzine.
- 17 Adjust idle speed (07.4—100).

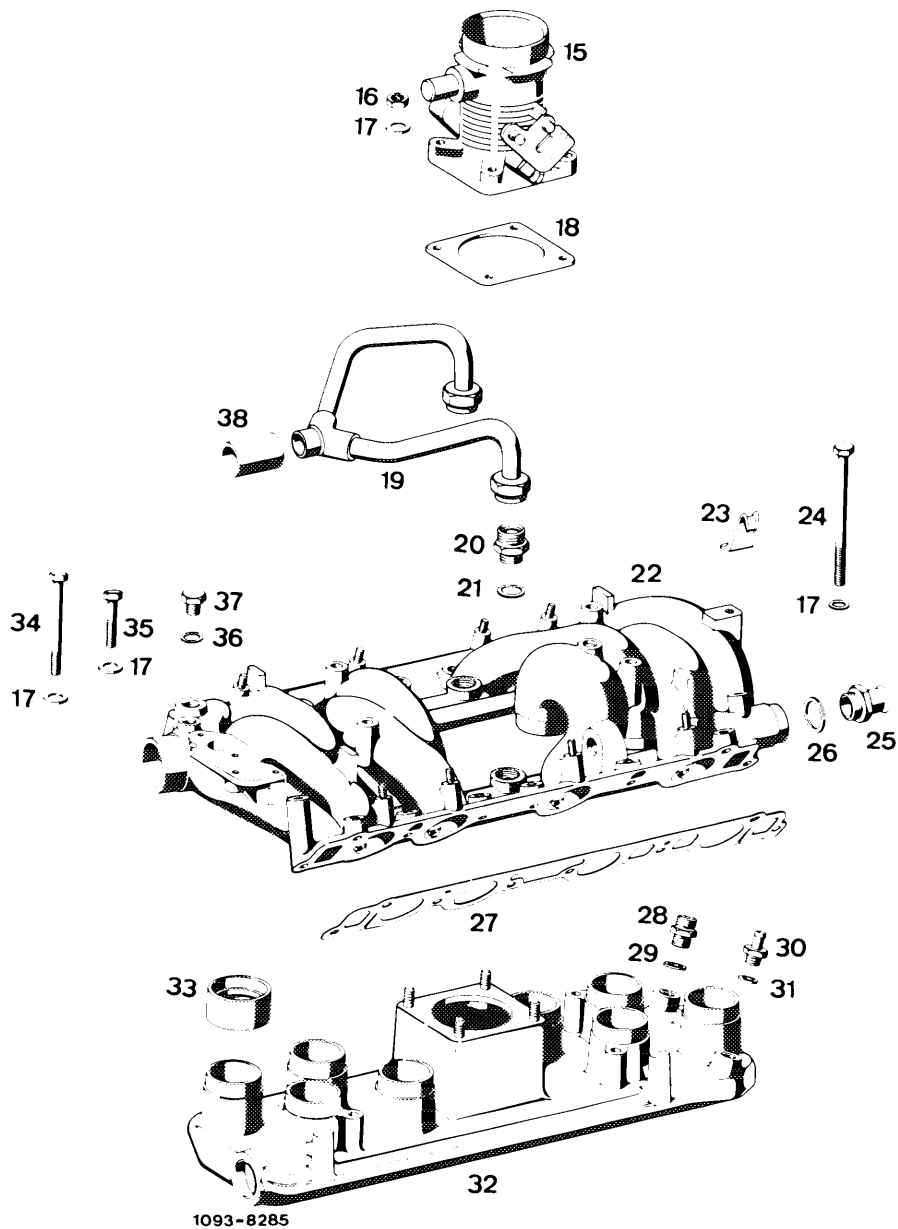

- | | | | |
|----|------------------------|----|------------------------|
| 15 | Throttle valve housing | 27 | Gasket |
| 16 | Nut | 28 | Screw connection |
| 17 | Washer | 29 | Sealing ring |
| 18 | Gasket | 30 | Screw connection |
| 19 | Idle speed air line | 31 | Sealing ring |
| 20 | Screw connection | 32 | Intake pipe lower half |
| 21 | Sealing ring | 33 | Rubber connection |
| 22 | Intake pipe upper half | 34 | Hex screw |
| 23 | Holder | 35 | Hex screw |
| 24 | Hex screw | 36 | Sealing ring |
| 25 | Connection | 37 | Closing plug |
| 26 | Sealing ring | 38 | Hose member |