

**Necked-down bolts for driven plates to crankshaft**

Necked-down bolts, part No.	116 032 02 71	116 032 04 71 <sup>1)</sup>
Thread D	M 12 x 1.5	
Necked-down shank dia. d	when new	9.8-0.2
	minimum dia.	9.3
Length L	23	29 <sup>1)</sup>

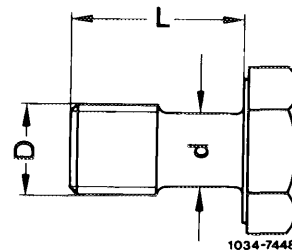

<sup>1)</sup> In case of repairs the crankshaft 1st version of model 107.026 with engine 117.960 can be replaced by the shorter crankshaft 117 031 14 01 together with a compensation plate (10.5 mm thick) and longer necked-down bolts (29 mm instead of 23 mm).

**Tightening torques**

Initial torque	30-40 Nm
Angle of rotation torque	90-100°

**Note**

The two driven plates (2nd and 3rd version) with 1.5 mm and 1.0 mm thickness differ with regard to the outer diameter from those of the engine 117.960 (1st version) with automatic transmission 722.006 and those of the cast-iron engines with 329 mm dia.

Engines with position indicator for the ignition (as of 1985) are equipped with a locating pin (24) and driven plates (17 and 18) with a bore for the locating pin. (3rd version)

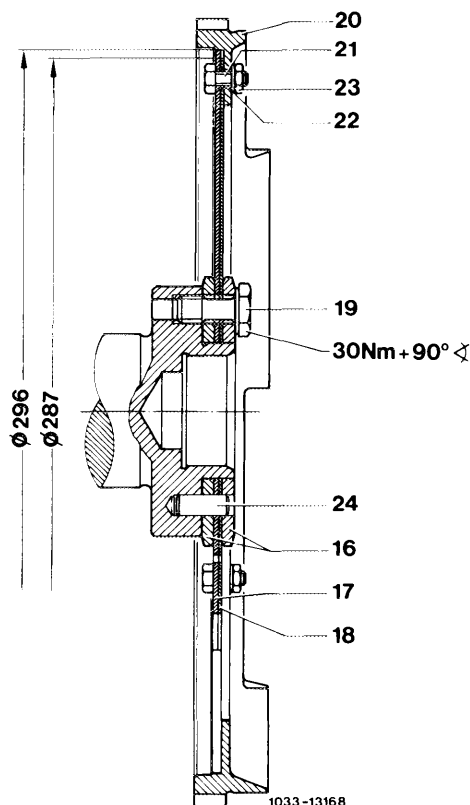

Arrangement engine 116.96, 117.96 (3rd version)

- 16 Plate 4.5 mm thick
- 17 Driven plate 1.5 mm thick, 296 mm dia.
- 18 Driven plate 1 mm thick, 287 mm dia.
- 19 Necked-down bolt
- 20 Ring gear
- 21 Fitted bolt
- 22 Spring washer B 6
- 23 Nut M 6
- 24 Locating pin

The previous hole of 8 mm dia. for the assembly of the locating pin (24) was enlarged to 8.5 mm in the plates (16).

The threaded holes in the crankshaft flange are through-holes. With the bolts removed and the engine inclined, oil will run out.

Arrangement engine 116.96, 117.96  
(2nd version)

- 16 Plate 4.5 mm thick
- 17 Driven plate 1.5 mm thick, 296 mm dia.
- 18 Driven plate 1 mm thick, 287 mm dia.
- 20 Ring gear
- 21 Fitted bolt
- 22 Spring washer B 6
- 23 Nut M 6

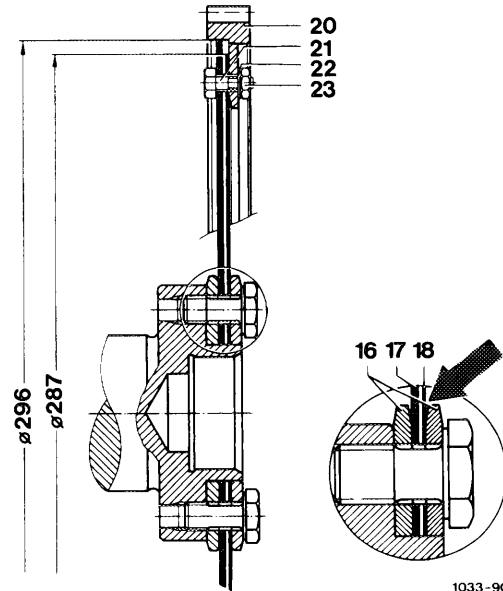

1033-9075

The arrangement of the driven plates on the engine 117.960 (1st version) with automatic transmission 722.006 up to engine end No. 001612, as well as engine end No. 001618–001635 and 001641–001681, corresponds with the arrangement for cast-iron engines.

Arrangement engine 117.960, 1st version

- 1 Plate 4.5 mm
- 2 Driven plate 1.5 mm, 329 mm dia.
- 3 Driven plate 1.0 mm, 329 mm dia.
- 4 Necked-down bolts L = 23 mm

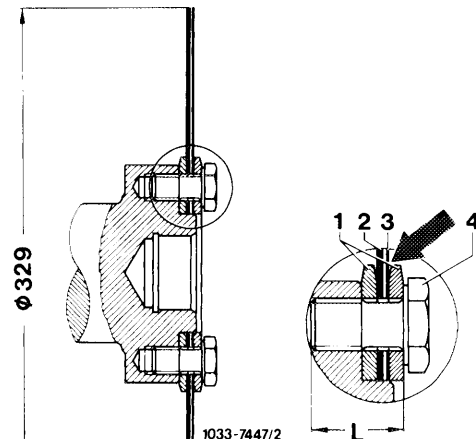

1033-7447/2

If during a repair the shorter crankshaft 117 031 14 01 is installed in the engine 117.960 (1st version) with automatic transmission 722.006, the compensating plate 10.5 mm thick, part No. 116 032 03 76 (arrow) should be used instead of the front plate, 4.5 mm thick, together with longer (L = 29 mm) necked-down bolts (6), part No. 116 032 04 71, (see arrangement engine 117.960 repair procedure with 1st version).

Arrangement engine 117.960, repair procedure with 1st version

- 1 Longitudinal compensation plate 10.5 mm
- 2 Driven plate 1.5 mm, 329 mm dia.
- 3 Driven plate 1.0 mm, 329 mm dia.
- 4 Plate 4.5 mm
- 6 Necked-down bolt L = 29 mm

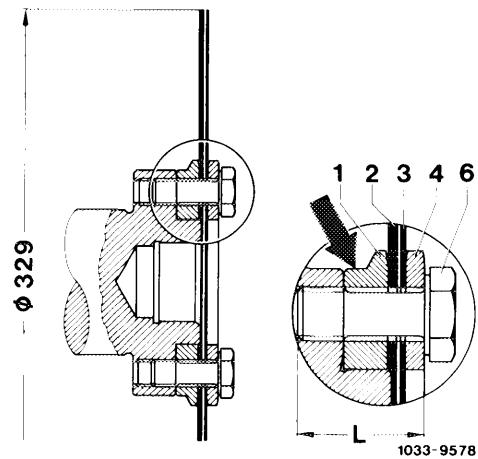

When using the longitudinal compensation plate together with the shortened crankshaft, the driven plate assembly must be centered with a self-fabricated centering sleeve before tightening the necked-down bolts.

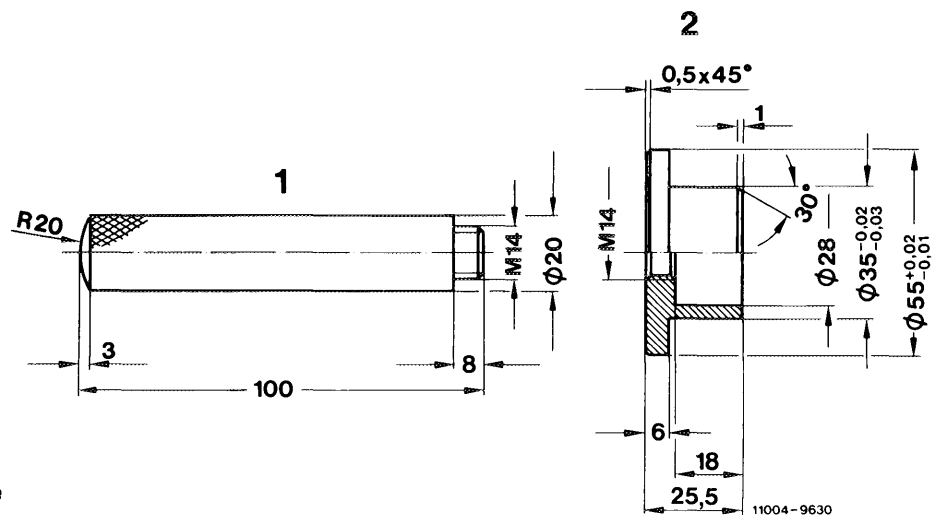

Self-fabricated centering sleeve

**Note:** Lighter driven plates and starter ring gears (version B) were installed in engines 116.962/963 and 117.962/963 during the period November 1982 to February 1983 and as of June 1983.

Designation	Version A	Version B
Driven plate, 1 mm thick	117 032 04 06	117 032 06 06
Driven plate 1.5 mm thick	117 032 05 06	117 032 07 06
Starter ring gear	117 030 03 12	117 030 04 12

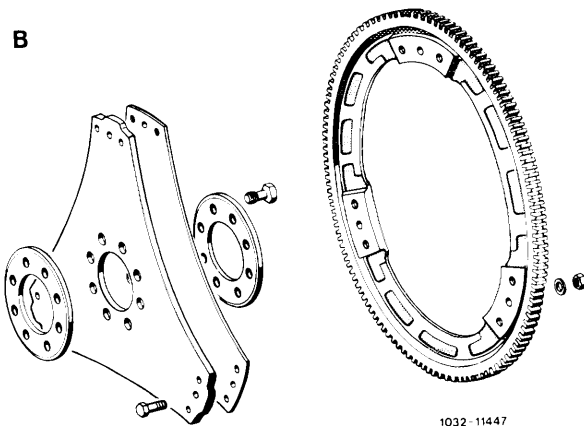
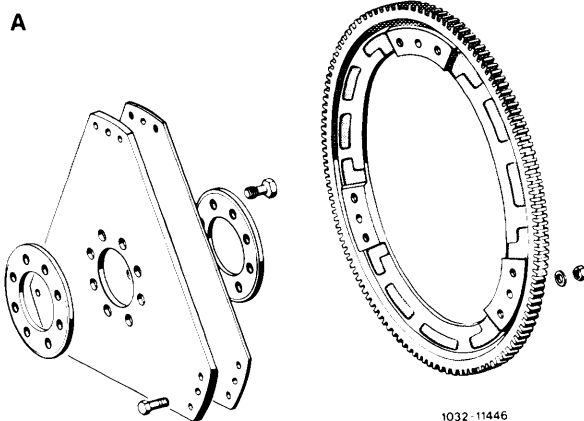

### Balancing

Crankshaft, V-belt pulley, vibration damper, driven plates and ring gear are individually balanced, and can be renewed without additional balancing.

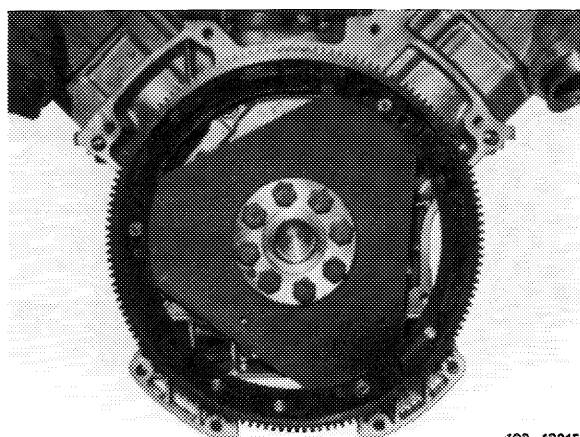

103-18215

## Removal

---

- 1 Remove transmission (27–600).
- 2 Unscrew necked-down bolts, spacer plates and driven plates with ring gear.

## Installation

---

- 3 Measure necked-down shank. If the specified minimum diameter „d“ on the necked-down shank is reached, the necked-down bolts must be renewed.

### Caution!

One of the eight mounting bolts is offset from the pitch circle diameter (arrow).  
The driven plates must therefore be installed in a certain position.  
The hole patterns must be matched accurately.

- 4 Screw in necked-down bolts and tighten with 30–40 Nm initial torque and 90–100° angle of rotation torque.

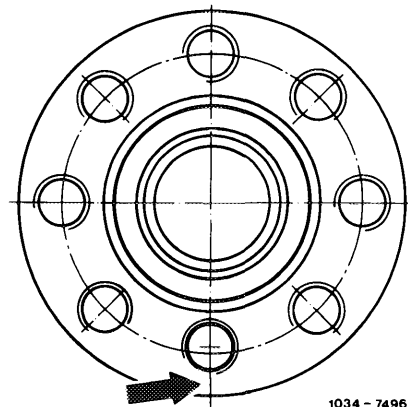

1034 - 7496

Lighter driven plates and ring gears (version B) were installed in the period November 1982 to February 1983 and as of June 1983.

Designation	Version A	Version B
Driven plate, 1 mm thick	117 032 04 06	117 032 06 06
Driven plate, 1.5 mm thick	117 032 05 06	117 032 07 06
Ring gear	117 030 03 12	117 030 04 12

In the case of repair, the version A of the ring gear must be replaced with the version B.

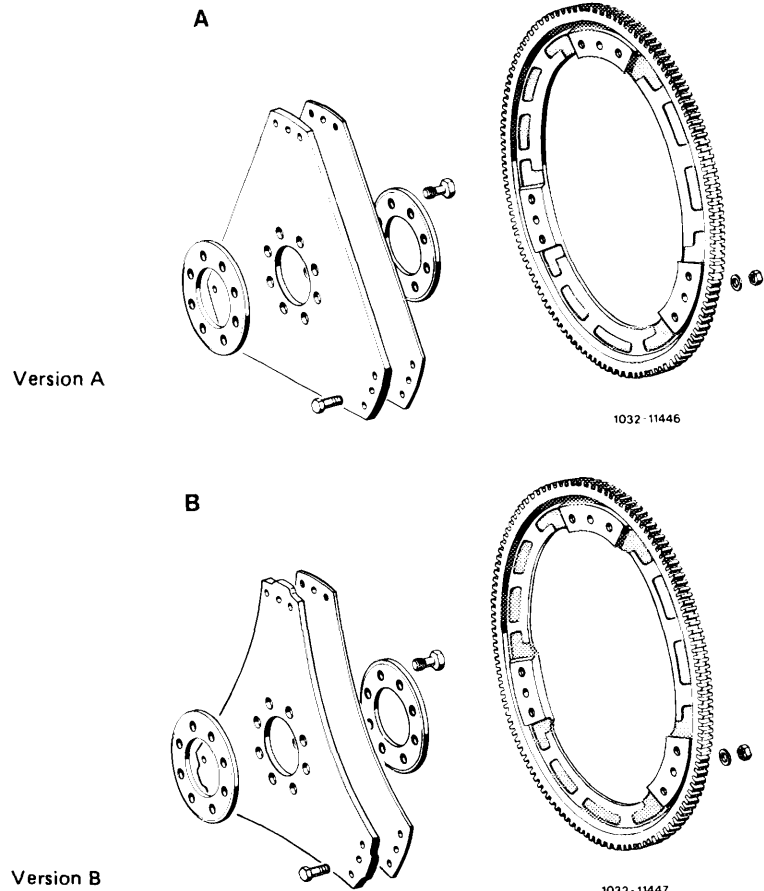

**B. Engine 117.960 with automatic transmission 722.006 (W 3 B 050)**

**Note**

When removing the transmission, the ring gear remains on the torque converter.

Ring gear with welded-on steel ring are balanced as a unit.