

07.3-205 Removal, reinstallation of fuel distributor

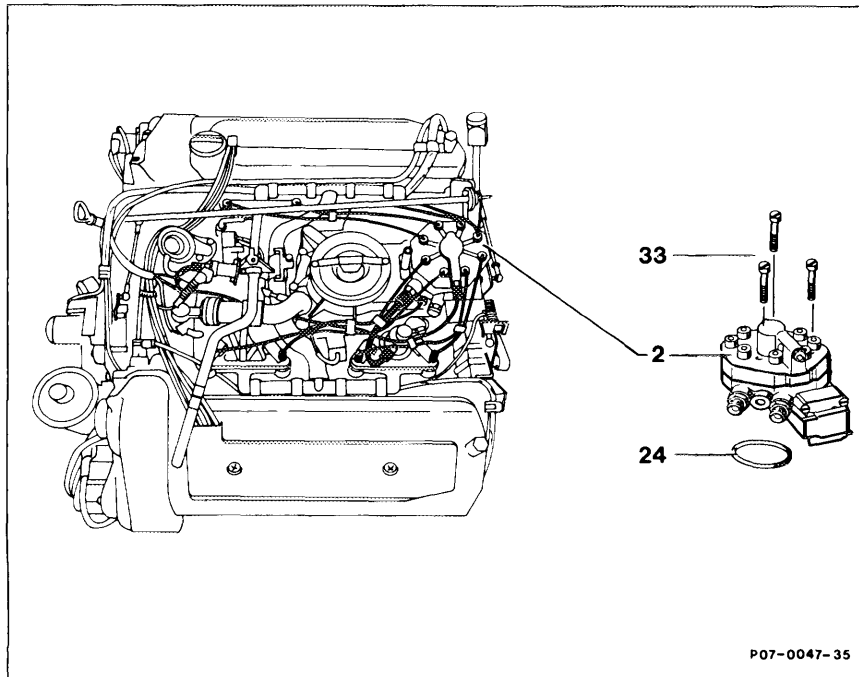

Fuel supply and return lines	disconnect, connect.
Injection lines	on fuel distributor and injection valves, disconnect, reconnect, 10-15 Nm (reference value).
Mounting screws (33)	remove, install.
Fuel distributor (2)	remove by turning backwards and forwards.
Rubber seal (24)	renew, fit dry. Carefully mount fuel distributor to avoid disturbing the rubber seal (24).
Basic position of control piston relative to sensor plate	check, adjust if required.
	Model 107, pull off coupling tail lamp cable harness 8-pole (X18) in footwell left below floor panel.
	Connect terminal 2 with terminal 30 (terminal block, next to overvoltage protection). Arrangement see figure.

Model 126, bridge jacks 7 and 8. Arrangement see Fig. The fuel pump will be supplied with voltage.

The fuel must now just stop or start flowing at the outlet fittings for the injection lines, adjust allocation with the idle speed mixture control screw if required.

Engine
 Idle speed

run, check all fuel connections for leaks.
 adjust (07.3-100).

Installation instructions

Adjust basic setting of control piston (2) by means of the idle speed mixture adjusting screw (61).

- 1 Screwdriver
- 2 Control piston
- 3 Adjusting device for lambda control/idle speed emission value
- 4 Safety plug
- 61 Adjusting screw

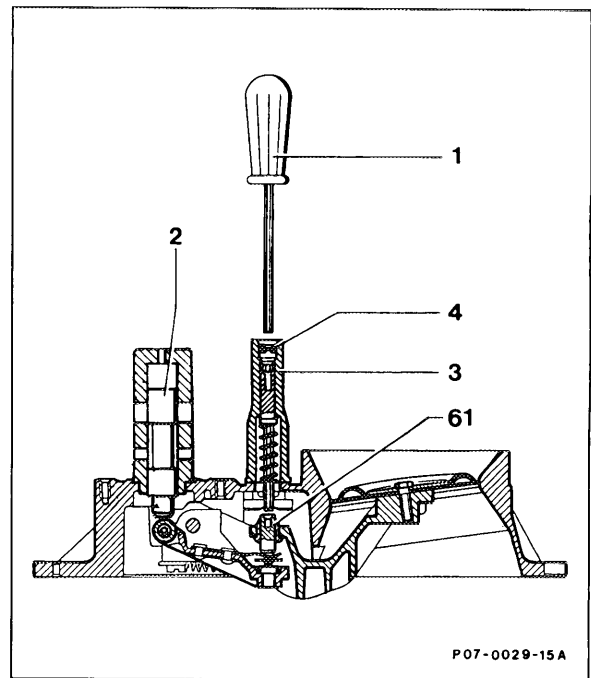

Location

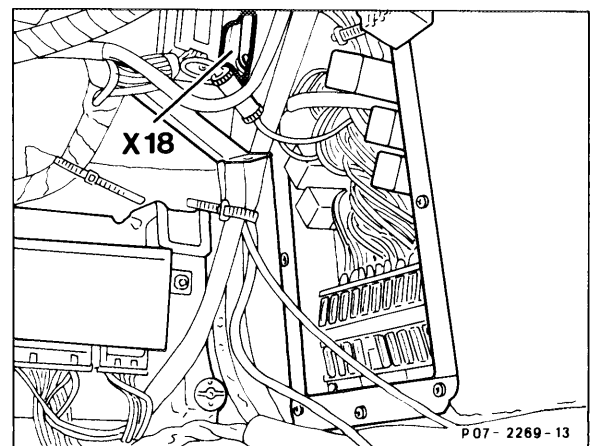

Model 107

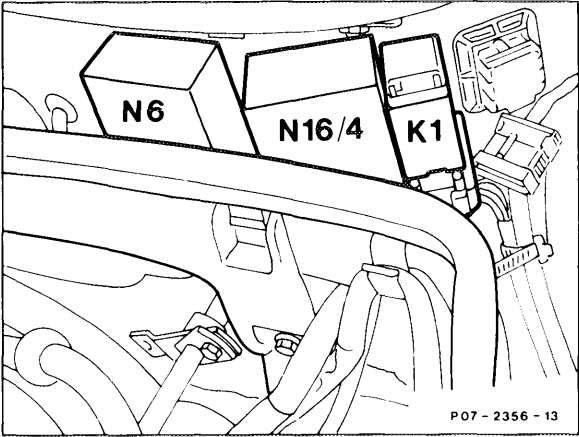

Model 126

P07 - 2356 - 13