

07.3-225 Removal, reinstallation of mixture control unit

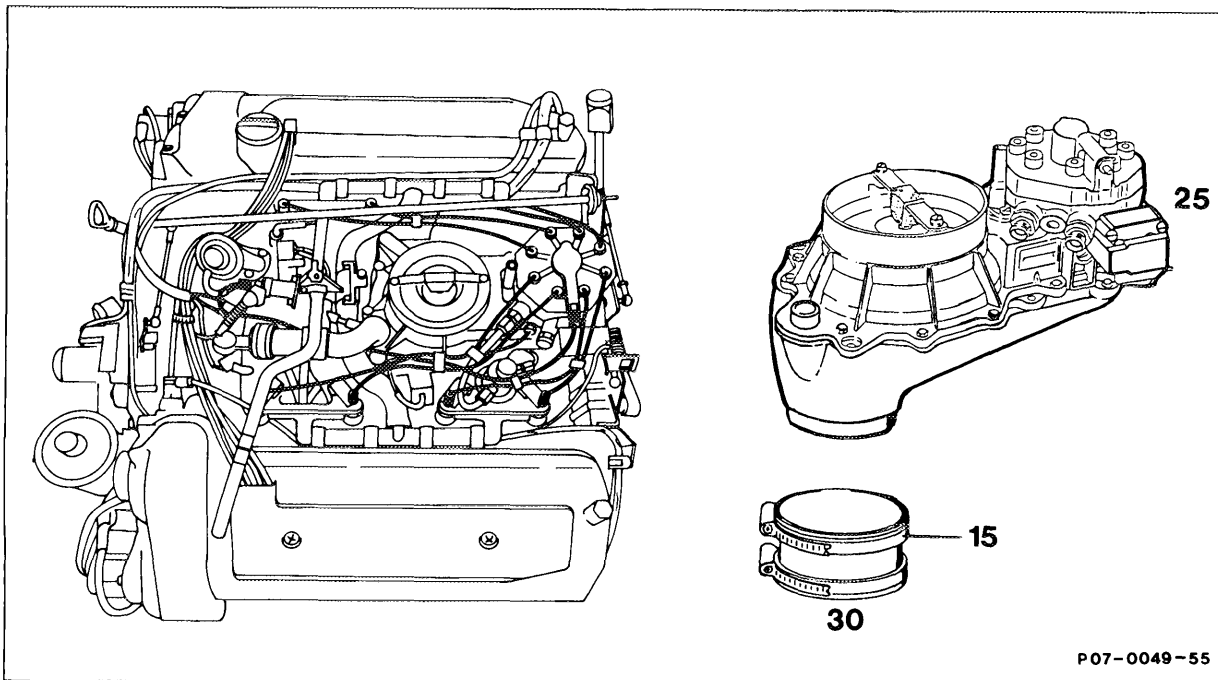

Fuel and injection lines	disconnect, connect. 10-15 Nm (reference value).
Electrical wiring	disconnect, reconnect.
Diaphragm pressure regulator	disconnect, reconnect.
Four mounting nuts for mixture control unit suspension on rubber buffers	remove, mount, 9-10 Nm (reference value).
Hose clamp (15) on throttle assembly	loosen, secure.
Mixture control unit (25) complete with air guide housing	lift off, fit.
Rubber buffer for attachment of air guide housing	check, renew according to condition.
Engine	run, check all fuel connections for leaks.
Idle speed	adjust

Note

Screws of different length are used to attach the air guide housing to the flow meter. For this reason it is imperative to ensure that the screw removed below the air flow sensor (arrow) is again installed in the same position. If a longer screw is used, the air flow sensor will be damaged.

