

47-120 Removing and installing fuel gauge sending unit

A. Model 107

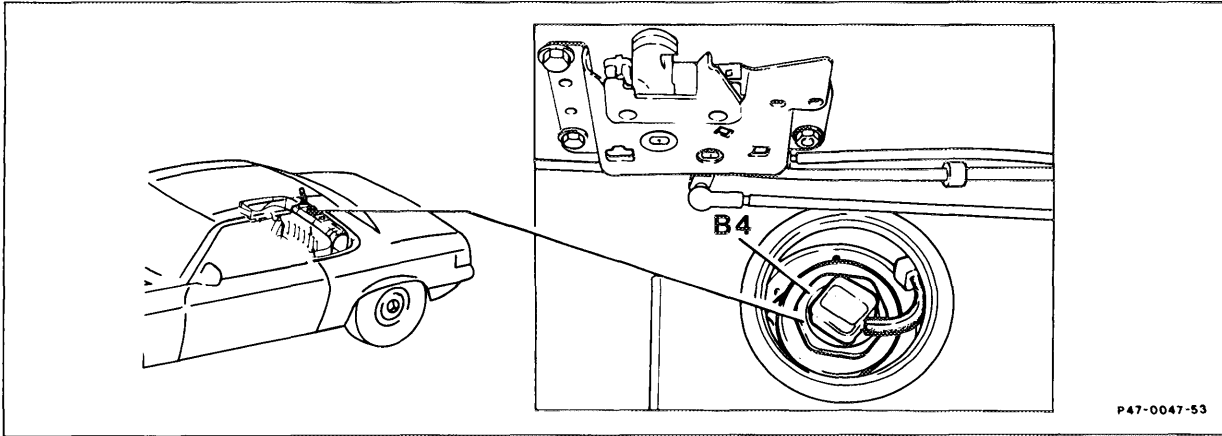

Battery ground cable	disconnect, connect.
Hardtop	detach, attach.
Soft top	raise, lower.
Cover	unclip, clip in.
Connector at fuel gauge sending unit (B4)	detach, protect against slipping off, plug in.
Fuel gauge sensor (B4)	remove and install, run to empty if necessary.

Note

If fuel tank full, pump off approx. 8 liters beforehand.
Renew seal.
Remove locking pin below adhesive sheet (new part).
Tightening torque 39 Nm.

B. Model 126

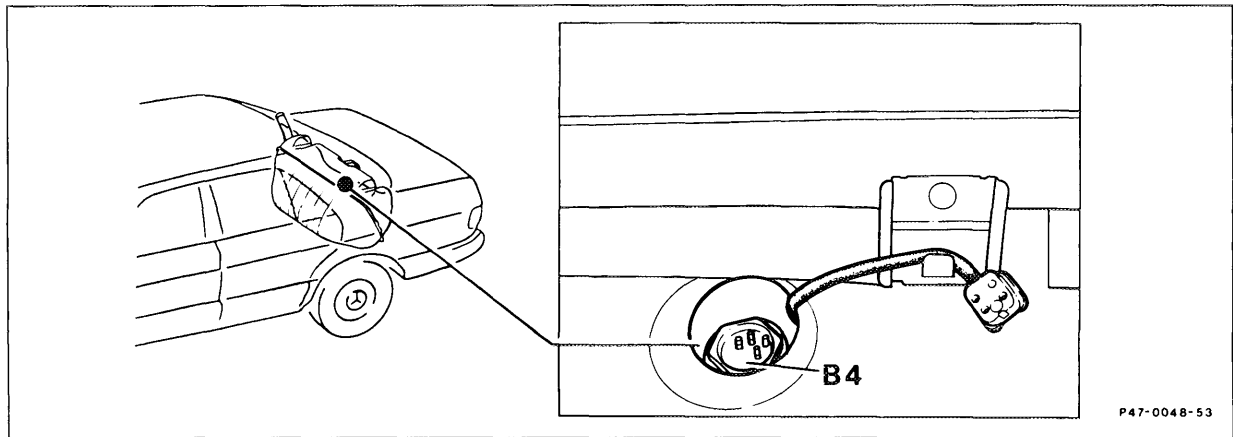

Battery ground cable	disconnect, connect.
Backrest, rear bench seat	remove and install (91-170).
Cover	unclip, clip in.
Connector on fuel gauge sensor (B4)	disconnect, protect against slipping off, plug in.
Fuel gauge sensor (B4)	remove and install, run to empty if necessary.

Note

If fuel tank full, pump off approx. 8 liters beforehand.

Renew seal.

Remove locking pin below adhesive sheet (new part only).

Tightening torque 39 Nm.

Special tool

