

All models

On separate order

Total capacity of cooling system and ratio of antifreeze to water in liters

| Model | Engine | Total capacity of cooling system incl. heater | Antifreeze protection to -37°C (50 Vol. -%) | Antifreeze protection to -45°C (55 Vol. -%) |
|-------|------------------|---|---|---|
| 107 | 116.96 | 12.5 | 6.25 | 7 |
| | 117.96 | 13.5 | 6.75 | 7.5 |
| 123 | 110, 616 | 10 | 5 | 5.5 |
| | 617.91 | 11 | 5.5 | 6 |
| | 617.95 | 12.5 | 6.25 | 7 |
| 124 | 103, 104, 602.96 | 9.5 | 4.75 | 5.25 |
| | 119 | 15.5 | 7.75 | 8.5 |
| | 603.96 | 10 | 5 | 5.5 |
| 126 | 103 | 8 | 4 | 4.4 |
| | 116.96 | 12.5 | 6.25 | 7.5 |
| | 117.96 | 13.5 | 6.75 | 7.5 |
| | 603.96/97 | 10 | 5 | 5.5 |
| | 617.95 | 12 | 6 | 6.5 |
| 129 | 104 | 11.5 | 5.75 | 6.3 |
| | 119 | 15 | 7.5 | 8.25 |
| | 120 | 15.5 | 7.75 | 8.5 |

| Model | Engine | Total capacity of cooling system incl. heater | Antifreeze protection to -37°C (50 Vol. -%) | Antifreeze protection to -45°C (55 Vol. -%) |
|-------|------------------------|---|---|---|
| 140 | 104 | 14.5 | 7.25 | 8 |
| | 119.970/971 | 16.5 | 8.25 | 9 |
| | 120 | 18.5 | 7.75 | 10.25 |
| | 603.96 | 10 | 5 | 5.5 |
| 201 | 102.961/985 601.921 | 8.5 | 4.25 | 4.75 |
| | 103.942 | 9.5 | 4.75 | 5.25 |
| | 102.983 602.911/961 | 8 | 4 | 4.5 |

Torque specifications (Nm)

| | |
|---|----------|
| Radiator drain plug, model 107 (w/o light alloy radiator) | 6-10 |
| Radiator drain plug, model 107 (w/ light alloy radiator), model 123, 124, 126, 129, 201 | 1.5-2 1) |

1) This torque can be achieved using a washer or coin.

Coolant

Coolant composition

50% by volume of water
50% by volume of corrosion protection/antifreeze agent.

Water

Use clean water that is not too hard. Usually, though not always, tap water meets these requirements. The dissolved substances in the water can contribute to corrosion. If in doubt, have the water analyzed.

Corrosion protection/antifreeze

Corrosion protection/antifreeze must provide the following:

- Adequate corrosion and cavitation protection for all components
- Antifreeze protection
- Higher boiling point.

Approx. 50% by volume of antifreeze must be added to the water. This concentration provides antifreeze protection down to approx. -37°C.

A higher concentration is only practical with even lower ambient temperatures.

Exceeding 55% by volume of corrosion protection/antifreeze agent reduces the antifreeze protection as well as the heat dissipating ability of the coolant.

55% by volume of corrosion protection/antifreeze agent provides antifreeze protection down to approx. -45°C.

Corrosion protection/antifreeze increases the boiling point, i.e. the coolant does not vaporize as rapidly. At high coolant temperatures, coolant boil over is avoided.

Use only approved corrosion protection/antifreeze.

Checking coolant in service

Before the start of the cold season, check the coolant for antifreeze protection.

In countries with high ambient temperatures, check corrosion protection/antifreeze concentration in coolant once a year.

When refilling (after coolant loss), ensure that the coolant contains 50% by volume of corrosion protection/antifreeze (protection down to -37°C).

The corrosion protection in the coolant diminishes during operation. The coolant then has a corrosive effect.

The coolant should be used for a maximum of **3 years**.

Before adding in new coolant, flush the old coolant from the cooling system.

For draining and filling of coolant, see repair instruction 20-010.

Disposal of coolant

Old coolant must be disposed of according to local laws and waste water or environmental regulations.

Engine block coolant drain locations

Engine 110 Right side of engine block to rear of engine mount bracket.

Engine 116, 117, 119 Right plug is forward of RH engine mount; left plug is forward of LH engine mount.

Engine 616, 617 Right side of engine block to rear of engine mount bracket, forward of starter.

Engine block coolant drain, engine 102

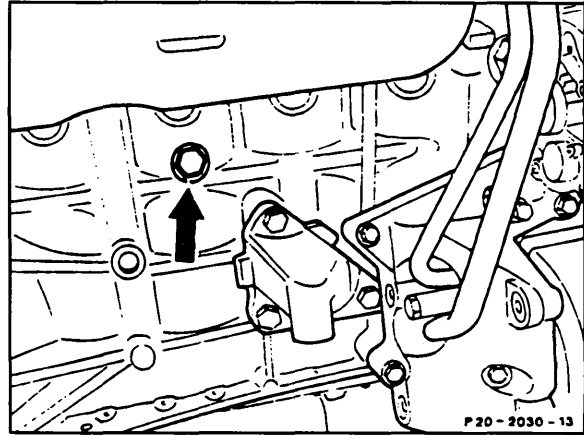

Engine block coolant drain (110) with drain hose attached, engine 103, 104

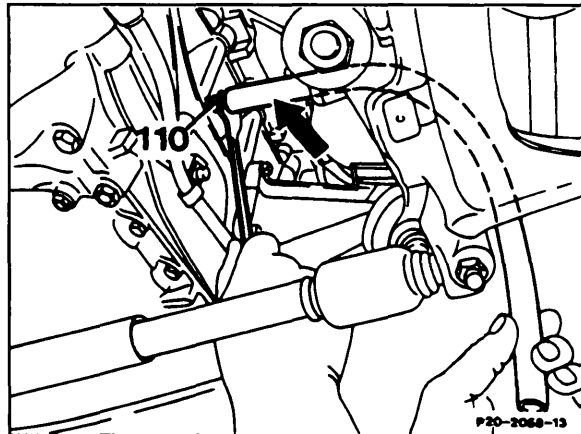

Engine block coolant drain, engine 120

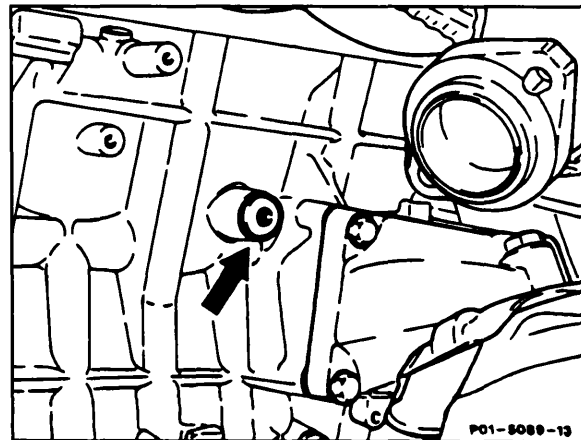

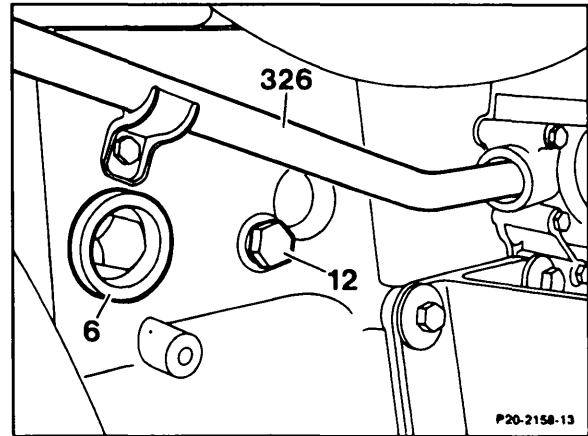

Engine block coolant drain (12), engine 601

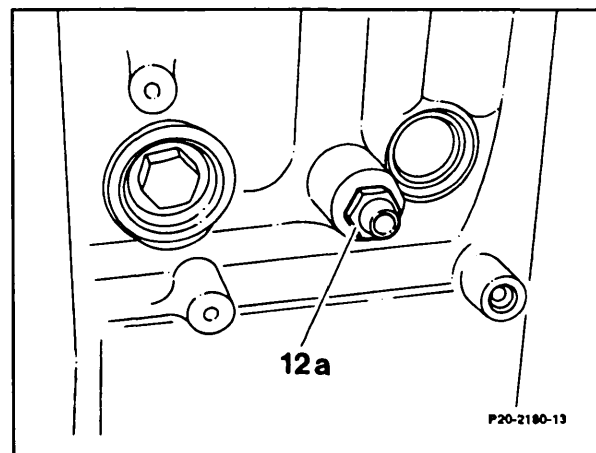

Engine block coolant drain (12a), engine 602, 603